



YOUR PARTNER IN CONSTRUCTION FORMWORK SOLUTIONS



VARIANT



www.variant-factory.eu



VARIANT

www.variant-factory.eu

VARIANT

CONTENTS

GENERAL INFORMATION	4
VARIANT WALL FORMWORK SYSTEMS	26
FRAMED FORMWORK	
Framed formwork VARIMAX	28
Lightweight framed formwork VARIMID	38
Lightweight framed formwork VARIECO	46
Super-lightweight framed formwork HANDI	52
TIMBER-BEAM FORMWORK	
Large-area formwork VERTEX 60	60
Adjustable circular formwork RINGFORM	70
COLUMN FORMWORK	
Circular column SK 100	78
Column formwork VARIMAX	84
Column formwork VARIMID	88
Column formwork HANDI	92
Column formwork VERTEX 60	94
SINGLE-SIDED FORMWORK	
Modular supporting frames	100
Adjustable supporting frames	108
VARIANT SLAB FORMWORK SYSTEMS	116
PROP SLAB FORMWORK	
Slab formwork VARIFLEX	118
TABLE SYSTEMS	
Formwork tables VARITABLE	124
Formwork tables VARITABLE PLUS	132
Slab props	140
VARIANT LOAD-BEARING SCAFFOLDING	
Load-bearing scaffolding TOPTOWER 40	150
Load-bearing scaffolding TOPTOWER 60	156
Load-bearing scaffolding TOPTOWER 100	162

VARIANT

CONTENTS

166	VARIANT CLIMBING FORMWORK
168	Crane-climbing formwork system CCF
172	Climbing working platform CWP
176	VARIANT SPECIAL FORMWORK SYSTEMS
178	Configurable tunnel system UNIFORM
188	Custom made formwork
190	VARIANT SAFETY SYSTEMS
	WORKING AND PROTECTION PLATFORMS
192	Folding brackets CWP
196	Shaft platform
	GUARDRAILS
200	Guard rail clamp
200	Handrail post
	ACCESS SYSTEMS
202	Stair tower TOPTOWER 40
206	REUSABLE PACKAGING
208	Packaging items



VARIANT

GENERAL INFORMATION

About Company



Variant Factory Ltd. is a part of a production corporation consisting of five enterprises involved in processes of metalworking such as blanking, rolling, cutting etc. and production of metalworking machinery.

The enterprise continuously strives to produce quality goods and provide professional services to meet expectations of each client. The level of customer service is constantly improved by means of permanent investments aimed at production plant modernization, diversification, quality control and improvement of employees' skills.

The result of these efforts is trust of hundreds of customers, including numerous well-known construction organizations, production enterprises and sales companies of Ukraine and other countries.

At present Variant Factory Ltd. offers the following formwork systems for concrete casting:

- wall formwork systems;
- slab formwork systems;
- systems for special purpose solutions.

Quality of the goods produced by Variant Factory is based on skillful labor, use of high quality domestic and imported raw materials as well as advanced level of production technologies. All the products meet the requirements of national standards, construction codes and regulations.



VARIANT FACTORY LTD.

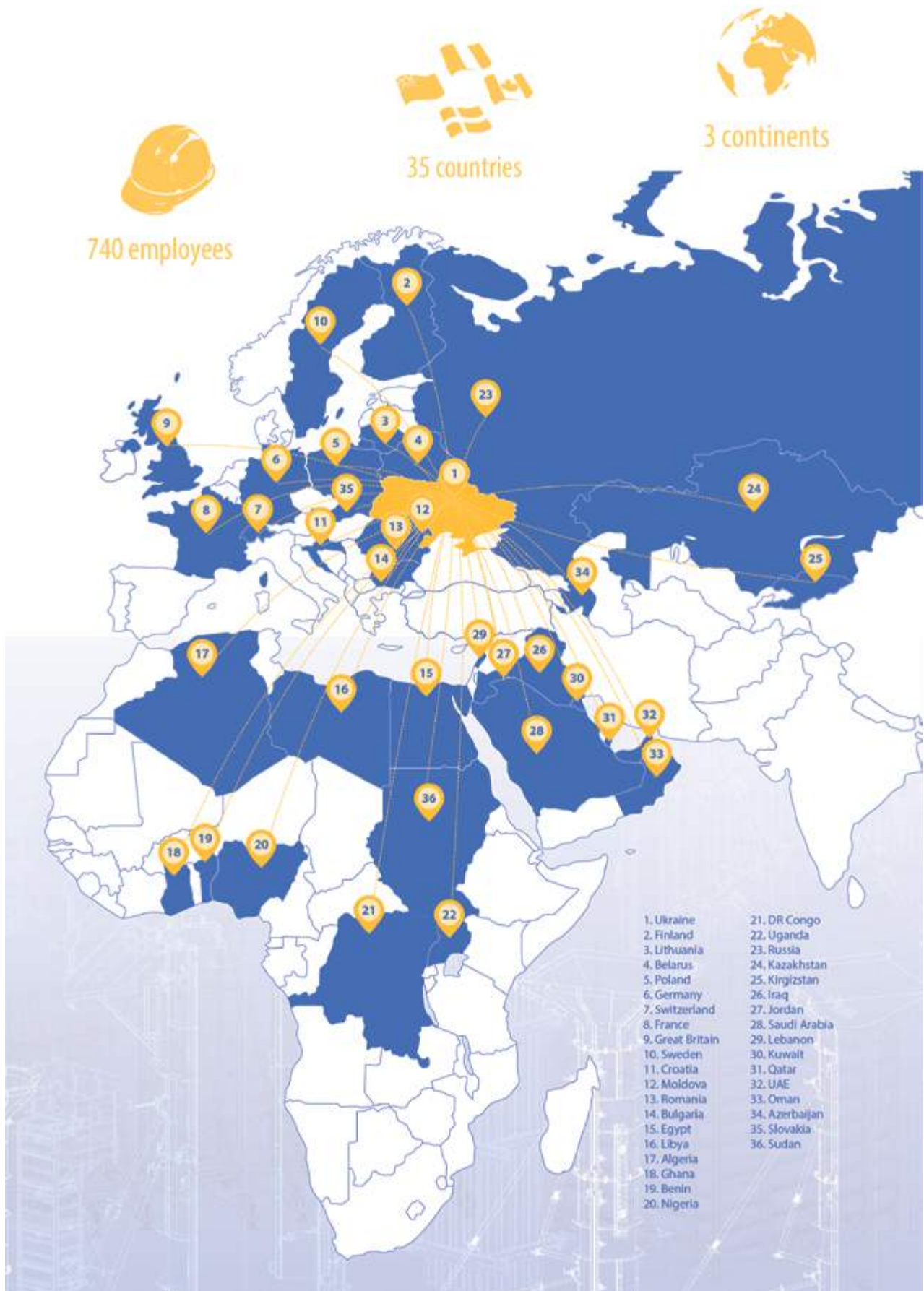

Foreign sales markets of Variant Factory

Variant has more than 20 years of experience in provision of practical and cost-effective formwork solutions for civil and industrial construction projects. As a result, the demand for products of Variant has increased in Ukrainian market as well as in the markets of the CIS countries, Middle East countries and countries of the European Union.

We are proud to cooperate with such countries as Finland, Russia, Lithuania, DR Congo, Belarus, Ukraine, Slovakia, Moldova, Kazakhstan, Kirgizstan, Iraq, Lebanon, Kuwait, Qatar, Libya, UAE, Saudi Arabia, Uganda, Nigeria, Ghana, Egypt, Germany, Poland, Benin, Jordan, Romania, Azerbaijan, Bulgaria, Switzerland, Croatia, Sweden, Oman, France and Great Britain.

We expand the scope of our contacts on daily basis:

- providing formwork solutions for construction projects of any complexity level;
- delivering our products to any destination;
- providing your projects with professional engineering support.

SAFETY MEASURES

Quality assurance procedures & safety measures

Due to the fact that Variant is always willing to demonstrate its ability to consistently provide products that meets customer and applicable statutory and regulatory requirements it has completed ISO 9001 Quality Management System certification.

According to the Quality Management System all the products manufactured by Variant Factory pass several stages of the control:

- new products testing – all new lines of the products are first produced as test samples for test department to be able to check quality and stability of the products.
- incoming inspection of all the raw materials and spare parts at the moment of their receipt.
- “first detail inspection” – each first detail (manufactured with new equipment, in the beginning of every new work shift, etc.) goes through this inspection, only after this workers can start production run.
- operational control – control, done after finishing of every operation – cutting, welding, painting, etc.
- final control – last stage control takes place before packing the material when the production cycle has been finished.
- logistic control - after container/truck has been loaded.

Variant devotes special attention to the professional skill of its employees, all the staff

of the Product Quality Department has been trained and certified in accordance with the requirements of ISO Quality Management System.

All the technical processes of production in the company are going under constant checking and control of certified experts in order to comply with requirements of safe and efficient production.

Elementary safety warnings

Variant provides every client in every project with appropriate technical information (e.g. shop drawing of formwork assembling, user manuals, instructions for assembly and use, technical catalogs etc.) and client is to ensure that all the material provided are available to all users and that they have been made aware of them.

The customer must ensure that Variant products are erected and dismantled, reset and generally used for their intended purpose under the direction and supervision of Variant's engineering team or suitably skilled persons with the authority to issue instructions.

The functional/technical instructions, safety warnings and loading data must all be strictly observed and complied with. Failure to do so can cause accidents and severe (even life-threatening) damage to health, as well as very great material damage.



OUR PROJECTS



Project development phase

Variant offers its partners a wide service package, providing support at all stages of project development and implementation.

To each project, developed by our partners, we pay maximum attention and responsibility. Variant's engineers closely study the technical characteristics of a project and offer the most optimal and cost-effective solution using different formwork and scaffolding systems.

The development of special formwork solutions

The Experts of Variant permanently design new lines of products. Also we provide special formwork solutions for non-standard construction projects.

Training and planning

Careful planning is the key to a successful project. Therefore, Variant experts are ready to provide support in all phases of your project:

- calculation and design of different formwork and scaffolding solutions;
- providing client's engineering staff with shop drawings, user manuals and other technical documentation;
- training the personnel of the companies using different Variant formwork and scaffolding systems;
- logistics solutions, etc.

Execution of construction work

International project experience allows Variant's specialists to take into consideration the smallest peculiarities of different regions and provide the most optimal and cost-effective solution for each and every project. Engineers and project managers provide support at all stages of construction.

OUR PROJECTS

Military Hospital, Al Qassim

Saudi Arabia

Systems in use:

- Framed formwork Varimax
- Large-area formwork Vertex 60
- Formwork tables Varitable
- Slab formwork Variflex
- Circular column SK 100
- Climbing working platform CWP
- Crane-climbing formwork system CCF
- Load-bearing scaffolding:
 - Top Tower 40
 - Top Tower 60





OUR PROJECTS

Al Shahad Tower, Doha Qatar

Systems in use:

- Large-area formwork Vertex 60
- Slab formwork Variflex
- Formwork tables Varitable
- Load-bearing scaffolding Top Tower 40

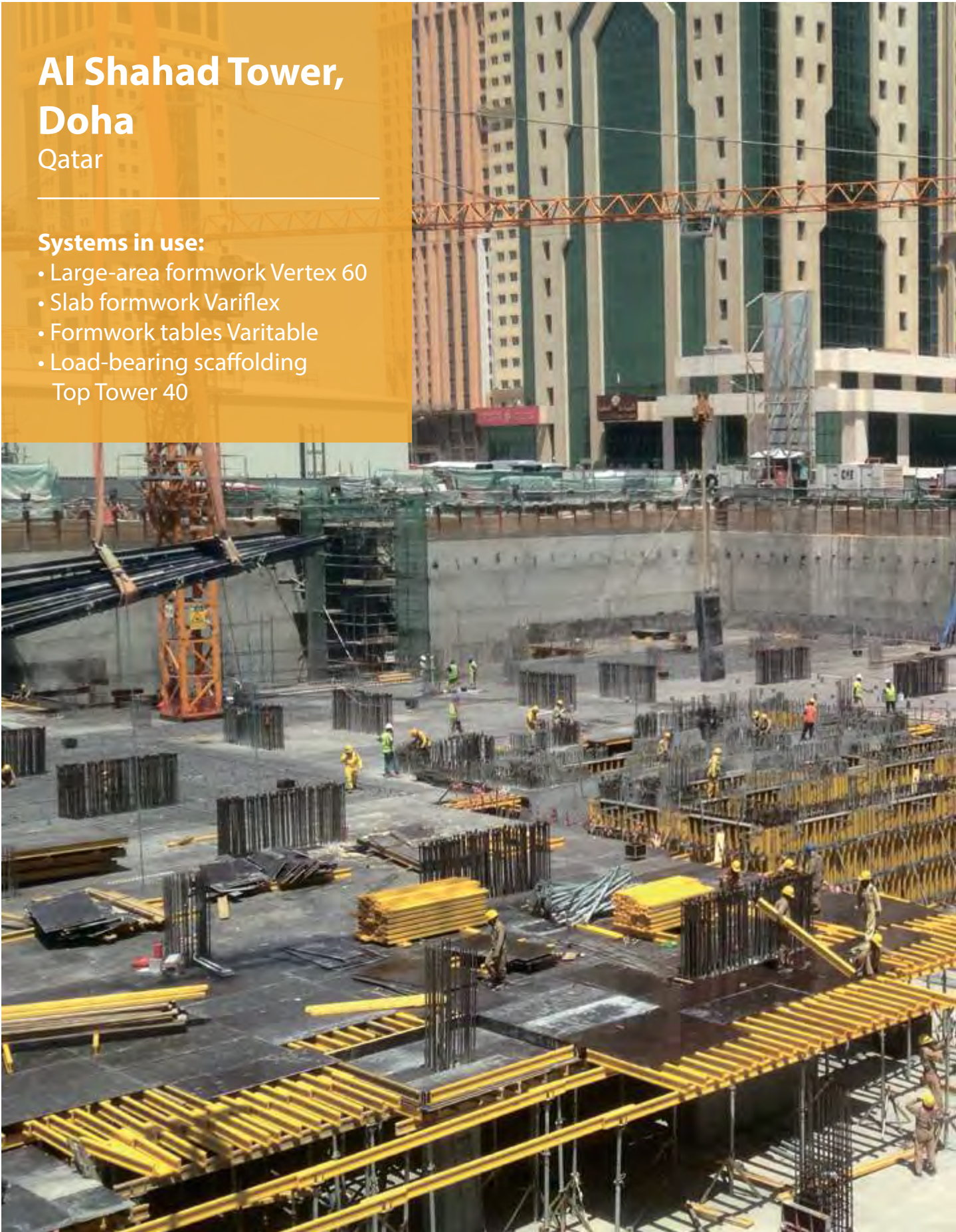



OUR PROJECTS

Maternity Hospital, Riyadh

Saudi Arabia

Systems in use:

- Framed formwork Varimax
- Large-area formwork Vertex 60
- Formwork tables Varitable
- Slab formwork Variflex
- Circular column SK 100
- Shaft platform
- Climbing working platform CWP
- Crane-climbing formwork system CCF
- Load-bearing scaffolding:
 - Top Tower 40
 - Top Tower 60





OUR PROJECTS

Development of ISF camp, Doha Qatar

Systems in use:

- Framed formwork Varimax
- Large-area formwork Vertex 60
- Slab formwork Variflex
- Load-bearing scaffolding:
Top Tower 40





OUR PROJECTS

PORT 19

Tammisaari
Finland

Systems in use:

- Framed formwork Varimax
- Super-lightweight framed formwork Handi





OUR PROJECTS

Residential Building, Kyiv Ukraine

Systems in use:

- Framed formwork Varimax
- Slab formwork Variflex

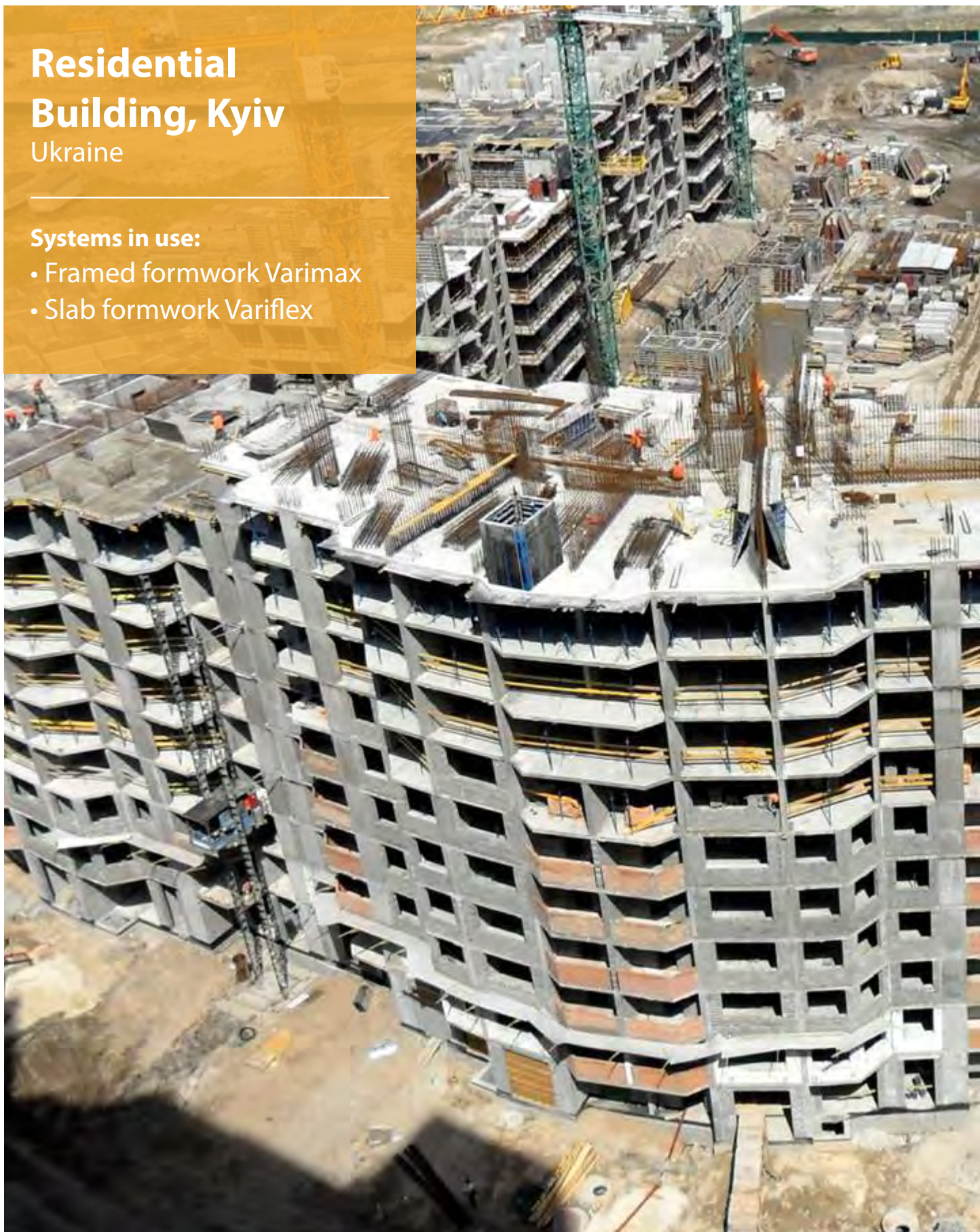





VARIANT

**WALL
FORMWORK
SYSTEMS**

Framed formwork VARIMAX

Tried and tested system designed to withstand high hydrostatic pressure of fresh concrete.

The framed formwork Varimax by Variant is a complete system, that includes accessories designed for heavy-duty use. The Varimax system ensures fast, safe and cost effective concreting process and provides you with an opportunity to make any concrete surface possible.

Heavy-duty formwork:

- 60 kN/m² pressure of fresh concrete acting on the whole area using a tie-rod system of 15.0 mm;
- 80 kN/m² pressure of fresh concrete acting on the whole area using a tie-rod system of 20.0 mm;
- High quality film faced plywood with a thickness of 21 mm. Film weight is 240 g/m².

Easy to use:

- It has only 5 standard panel widths that provides for easier planning and forming process;
- All the connectors and accessories are easily fixed in the slots and quickly tighten, thus maximizing and making forming time efficient.

Cost-effective:

- Installation of pre-assembled units reduces necessity of crane use to minimum;
- High number of use cycles results in lower follow-up expenses;
- Reduction of expenses due to possibility of restoration and cleaning;
- Galvanized or powder-coated steel frames provide for long service life;
- High quality of concrete surface reduces finishing work to minimum.

Safe use:

- Such accessories as — lifting hooks, wall brackets, supporting struts etc. make the system handling safer and easier.





VARIMAX panels

Heights and widths of the Varimax panels provide for availability of a logical and advantageous increment-grid. Small range of panel sizes makes planning easier and forming faster.

- 5 widths of panel
- 5 heights of panel
- 5 extra-large panels

For any panel type and size there are two options of covering available.



Galvanized

Powder-coated

STANDARD PANEL HEIGHTS

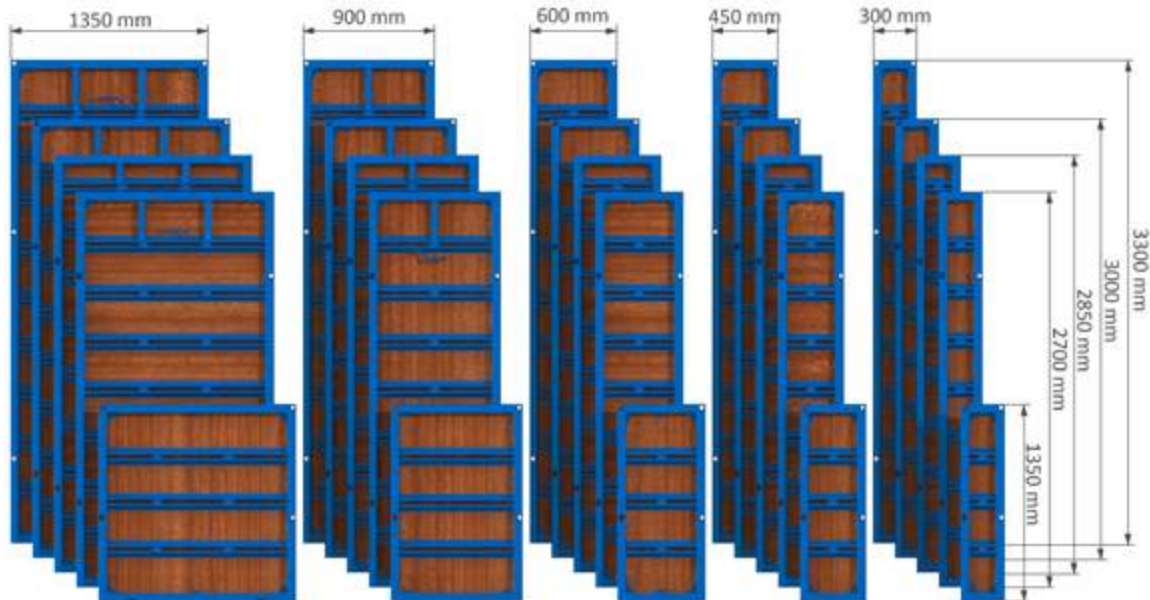

Two options of external profile available:

Varimax profile

Varimax P profile

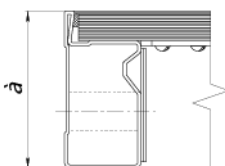
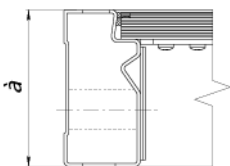

$a = 123 \text{ mm}$

$a = 123 \text{ mm}$



EXTRA-LARGE PANELS

- Intended for use with large-area wall forming.
- Fewer connectors and accessories are needed.
- May be installed vertically or horizontally.

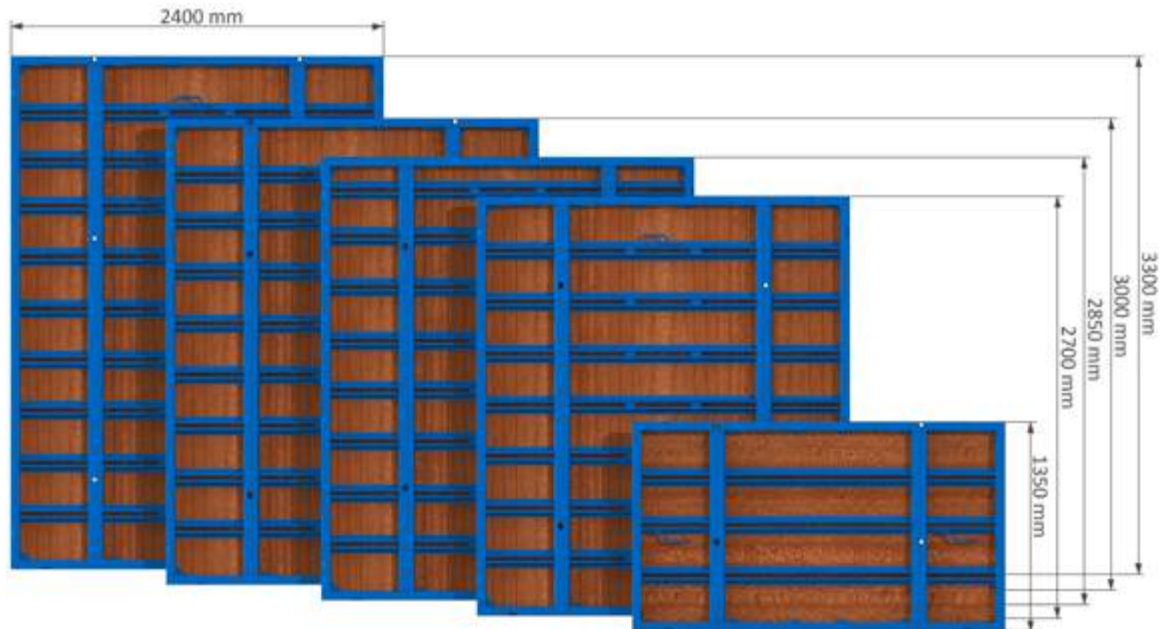

VERSATILE PANELS

Special hole pattern makes these panels particularly suitable for efficient forming of:

- Corners;
- Wall junctions;
- Stop-ends;
- Columns.

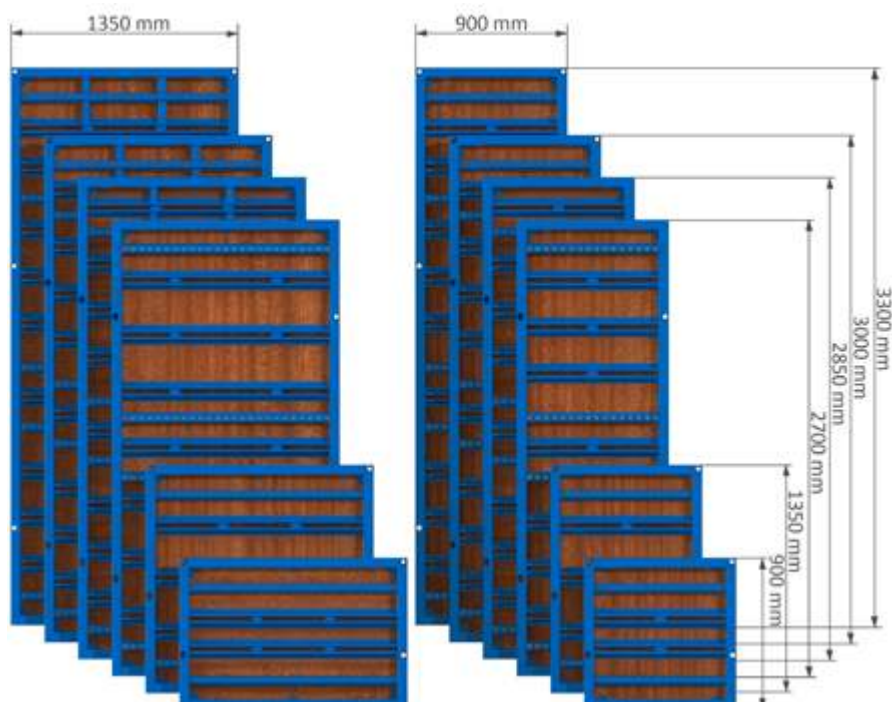

VARIMAX panel connection

JOINING

Due to a continuous slot provided along the whole panel profile, a clamp device can be installed in any desired point, simply with a blow of the hammer. This makes assembly super-fast and no special tools required.

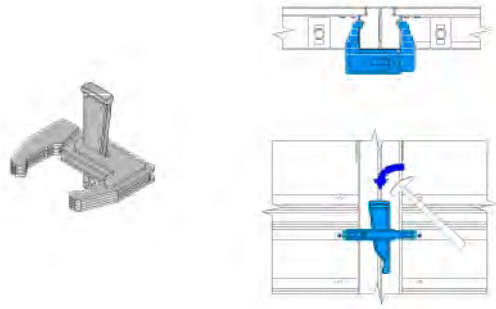

CLOSURES

Closures are intended for use in places where formwork cannot be easily stricken. It is filled with construction timber and tightened with the use of an adjustable clamp device.

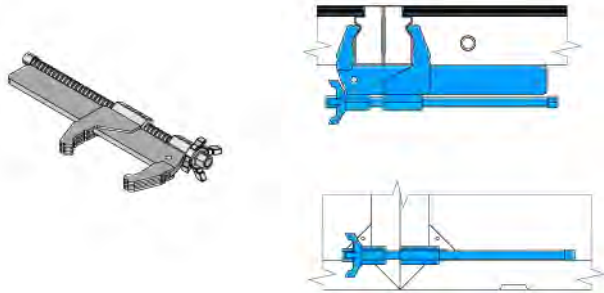

VERTICAL STAKING

With the use of guide plates or steel walings fixed with contact devices, the panels can be easily assembled in large and rigid gang-form in order to be put up and set down by crane.

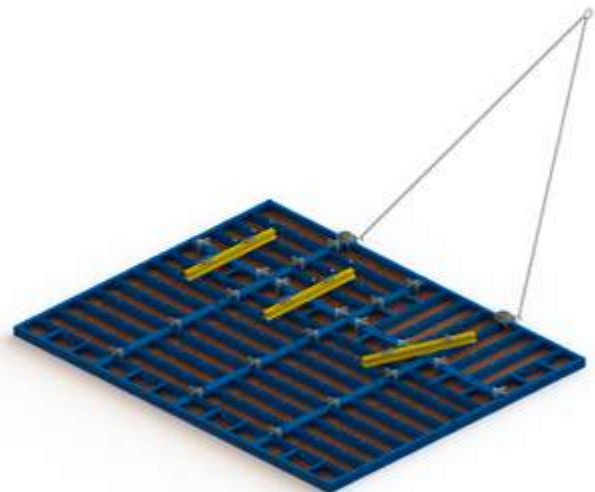

TYING

The large, conical form-tie sleeves in the panels provide for their ability to be stood at an angle on one or both sides, and to be height-mismatched.

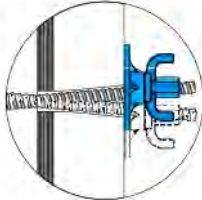

Conical on 1 side

Conical on both sides

Conical on 1 side

max. 4°

max. 2 x 4.5°

Form-tie system 15.0:
max. 1.9 cm
 per 10 cm of wall thickness
 Form-tie system 20.0:
max. 1.0 cm
 per 10 cm of wall thickness

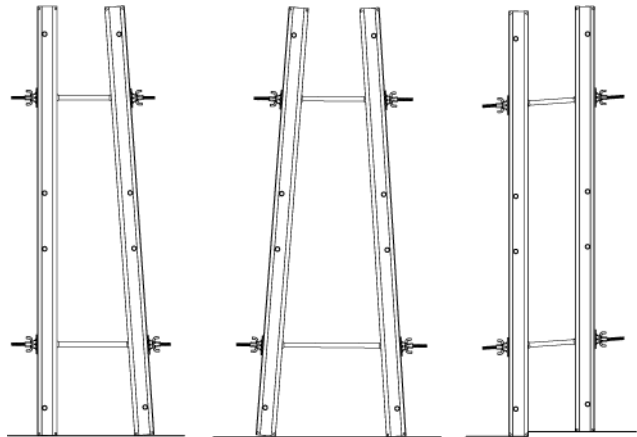





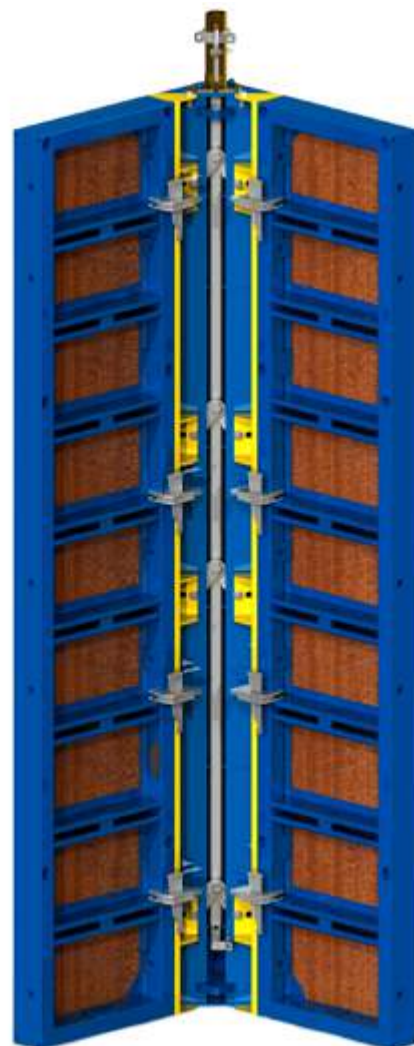
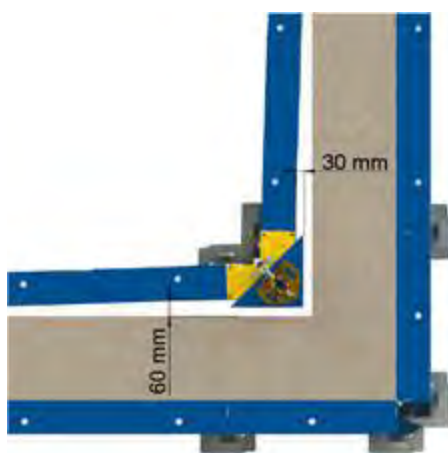



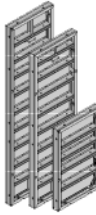

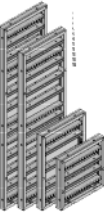
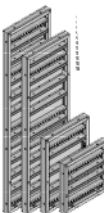

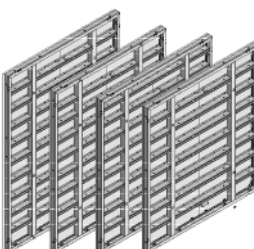
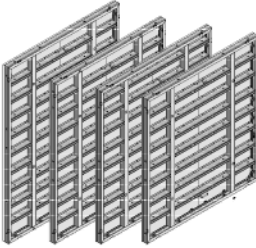



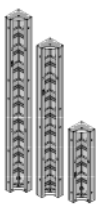
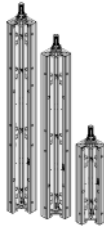

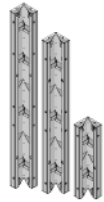
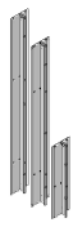

STRIPPING CORNER

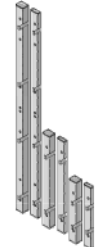
The Varimax stripping corner was specially designed for the use with shaft formwork. It provides for formwork to be closed and opened in accordance with accident protection regulations, i.e. without crane, simply by operating easy-to-turn spindles with a reinforcement rod or convenient ratchet. It is then lifted and reinstalled in one piece, thus saving crane-operation time. The Varimax stripping corner is also suitable for use on pilasters and as an inside corner on wall formwork.

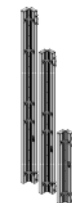











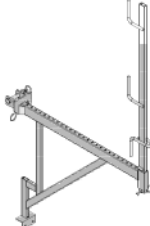
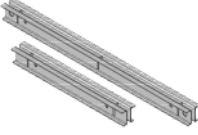







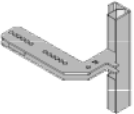









VARIMAX

Item	[kg]	Article n°	Item	[kg]	Article n°		
Standard panel Varimax  Options available: xx xxx 000 - Powder coated; xx xxx 100 - Galvanized; xx xxx 200 - Hot dip galvanized; Custom size on request	1.35x3.30m	260,40	11 104 000	Standard panel Varimax P  Options available: xx xxx 000 - Powder coated; xx xxx 100 - Galvanized; xx xxx 200 - Hot dip galvanized; Custom size on request 	15 104 000		
	0.90x3.30m	183,33	11 108 000		15 108 000		
	0.60x3.30m	127,05	11 110 000		15 110 000		
	0.45x3.30m	101,85	11 112 000		15 112 000		
	0.30x3.30m	80,85	11 114 000		15 114 000		
	1.35x3.00m	236,25	11 204 000		15 404 000		
	0.90x3.00m	166,70	11 208 000		15 408 000		
	0.60x3.00m	114,45	11 210 000		15 410 000		
	0.45x3.00m	97,65	11 212 000		15 412 000		
	0.30x3.00m	76,65	11 214 000		15 414 000		
	1.35x2.85m	231,00	11 304 000		15 504 000		
	0.90x2.85m	161,70	11 308 000		15 508 000		
	0.60x2.85m	123,59	11 310 000		15 510 000		
	0.45x2.85m	95,78	11 312 000		15 512 000		
	0.30x2.85m	74,26	11 314 000		15 514 000		
	1.35x2.70m	221,00	11 404 000		15 404 000		
	0.90x2.70m	143,82	11 408 000		15 408 000		
	0.60x2.70m	105,63	11 410 000		15 410 000		
	0.45x2.70m	86,42	11 412 000		15 412 000		
	0.30x2.70m	63,19	11 414 000		15 414 000		
	1.35x1.35m	108,36	11 504 000		15 504 000		
	0.90x1.35m	88,04	11 508 000		15 508 000		
	0.60x1.35m	56,62	11 510 000		15 510 000		
	0.45x1.35m	46,40	11 512 000		15 512 000		
	0.30x1.35m	36,24	11 514 000		15 514 000		
	1.35x0.90m	54,00	11 604 000		15 604 000		
	0.90x0.90m	43,87	11 608 000		15 608 000		
	0.60x0.90m	36,90	11 610 000		15 610 000		
0.45x0.90m	30,20	11 612 000	15 612 000				
0.30x0.90m	23,60	11 614 000	15 614 000				
							
Versatile panel Varimax  Options available: xx xxx 000 - Powder coated; xx xxx 100 - Galvanized; xx xxx 200 - Hot dip galvanized; Custom size on request	1.35x3.30m	298,20	11 102 000	Versatile panel Varimax P  Options available: xx xxx 000 - Powder coated; xx xxx 100 - Galvanized; xx xxx 200 - Hot dip galvanized; Custom size on request 	15 102 000		
	1.35x3.00m	281,40	11 202 000		15 402 000		
	1.35x2.85m	268,28	11 302 000		15 502 000		
	1.35x2.70m	258,62	11 402 000		15 106 000		
	1.35x1.35m	128,63	11 502 000		184,12		
	1.35x0.90m	95,80	11 602 000		94,74		
	0.90x3.30m	218,40	11 106 000				
	0.90x3.00m	178,50	11 206 000				
	0.90x2.85m	166,95	11 306 000				
	0.90x2.70m	184,12	11 406 000				
	0.90x1.35m	90,36	11 506 000				
	0.90x0.90m	67,20	11 606 000				
							
	Extra-large panel Varimax  Options available: xx xxx 000 - Powder coated; xx xxx 100 - Galvanized; xx xxx 200 - Hot dip galvanized; Custom size on request	2.40x3.30m	500,85		11 100 000	Extra-large panel Varimax P  Options available: xx xxx 000 - Powder coated; xx xxx 100 - Galvanized; xx xxx 200 - Hot dip galvanized; Custom size on request 	15 100 000
		2.40x3.00m	435,60		11 200 000		15 400 000
		2.40x2.85m	472,95		11 300 000		15 500 000
		2.40x2.70m	407,40		11 400 000		585,84
		2.40x1.35m	212,32		11 500 000		476,50
							

Item		[kg]	Article n°	Item		[kg]	Article n°
Internal angle Varimax 	0.30x3.30m	121,80	11 710 000	Stripping corner Varimax 	0.30x3.30m	207,90	11 718 000
	0.30x3.00m	114,17	11 720 000		0.30x3.00m	190,30	11 728 000
	0.30x2.85m	108,47	11 730 000		0.30x2.85m	176,20	11 738 000
	0.30x2.70m	103,49	11 740 000		0.30x2.70m	168,70	11 748 000
	0.30x1.35m	51,90	11 750 000		0.30x1.35m	97,65	11 758 000
	0.30x0.90m	36,07	11 760 000				
Options available: xx xxx 000 - Powder coated; xx xxx 200 - Hot dip galvanized; Custom size on request				Options available: xx xxx 000 - Powder coated; xx xxx 200 - Hot dip galvanized; Custom size on request			
Joint angle internal Varimax 	0.30x3.30m	141,23	11 712 000	Expansion block Varimax 	3.30m	68,69	11 810 000
	0.30x3.00m	129,15	11 722 000		3.00m	62,30	11 820 000
	0.30x2.85m	120,44	11 732 000		2.85m	59,33	11 830 000
	0.30x2.70m	116,55	11 742 000		2.70m	57,77	11 840 000
	0.30x1.35m	61,36	11 752 000		1.35m	28,10	11 850 000
	0.30x0.90m	41,16	11 762 000				
Options available: xx xxx 000 - Powder coated; xx xxx 200 - Hot dip galvanized; Custom size on request				Options available: xx xxx 000 - Powder coated; xx xxx 200 - Hot dip galvanized; Custom size on request			
External angle Varimax 	3.30m	60,69	11 714 000	Steel closure plate Varimax 	0.10x3.30m	40,10	11 812 000
	3.00m	54,50	11 724 000		0.10x3.00m	36,45	11 822 000
	2.85m	51,98	11 734 000		0.10x2.85m	34,60	11 832 000
	2.70m	49,35	11 744 000		0.10x2.70m	32,80	11 842 000
	1.35m	24,26	11 754 000		0.10x1.35m	16,40	11 852 000
Options available: xx xxx 000 - Powder coated; xx xxx 200 - Hot dip galvanized; Custom size on request				Options available: xx xxx 000 - Powder coated xx xxx 200 - Hot dip galvanized Custom size on request			
Joint angle external Varimax 	3.30m	64,68	11 716 000	Stripping spindle Varimax 		3,71	11 942 100
	3.00m	58,83	11 726 000				
	2.85m	54,08	11 736 000				
	2.70m	52,88	11 746 000				
	1.35m	27,25	11 756 000				
Options available: xx xxx 000 - Powder coated; xx xxx 200 - Hot dip galvanized; Custom size on request							
				Lifting hook LH-H-1t Varimax 		10,34	11 924 000
					 		EN 13155 EN ISO 12100 EN 349

VARIMAX

Item	[kg]	Article n°	Item	[kg]	Article n°
Clamp device Varimax 	3,90	11 902 100	Panel holder Varimax 	1,84	11 922 000
Adjustable clamp Varimax 	6,00	11 904 100	Wall bracket Varimax 	13,28	11 926 100
Guide plate 	0.90m 1.50m	11,35 18,85	Guide rail clamp 	12,40	52 400 100
Corner guide plate 	0.60x0.60m	14,04	Supporting strut 340 	37,38	11 928 100
Contact device 	1,49	11 918 100	Supporting strut 540 	56,91	11 930 100
Stop-end tie Varimax 	1,76	11 906 100			
Connection screw 	10-16 10-25	0,63 0,79			
Transition plate 	12/18 12/21 10/18 10/21	18,70 19,05 17,90 18,25			

Item	[kg]	Article n°	Item	[kg]	Article n°		
Adjustable plumbing strut 			Tie holder Varimax 	1,30	11 920 000		
			Plastic tube 22 mm 	2.00m	0,36	99 100 400	
			Plastic cone 22 mm 		0,005	99 102 400	
Spindle head 	3,48	11 932 100	Tie rod 15.0 mm 	0,50m	0,80	92 050 300	
Spindle element without end-hinge 	36,62	11 934 000		0,75m	1,20	92 075 300	
Extension strut 3.70 m 	78,75	11 936 000		1,00m	1,60	92 100 300	
Extension strut 2.40 m 	54,13	11 938 000		1,25m	2,00	92 125 300	
Spindle element with end-hinge 	43,81	11 940 000		1,50m	2,40	92 150 300	
				1,75m	2,80	92 175 300	
Superplate 	15	1,22	95 200 100	2,00m	3,20	92 200 300	
	20	2,10	95 202 100	2,25m	3,60	92 225 300	
Star-shaped nut 	15	0,40	95 206 100	2,50m	4,00	92 250 300	
				2,75m	4,40	92 275 300	
				3,00m	4,80	92 300 300	
				6,00m	9,60	92 600 300	
				Tie rod 20.0 mm 	0,50m	1,20	93 050 300
				0,75m	1,80	93 075 300	
				1,00m	2,40	93 100 300	
				1,25m	3,00	93 125 300	
				1,50m	3,60	93 150 300	
				1,75m	4,20	93 175 300	
Hexagon nut 	15	0,37	95 208 100	2,00m	4,80	93 200 300	
				2,25m	5,40	93 225 300	
				2,50m	6,00	93 250 300	
				2,75m	6,60	93 275 300	
				3,00m	7,20	93 300 300	
				Plug for anchoring holes Varimax 	0,008	11 990 400	
				Pressure plate 	0,86	95 210 100	Plug for versatile holes Varimax 

Framed formwork VARIMID

Tried and tested system designed for forming when the crane use is limited.

The framed formwork Varimid by Variant is a complete system with accessories included that delivers perfect forming performance on construction sites with the limited crane use. High load-bearing capacity and long service life of Varimid system makes it a cost-effective solution.

High load-bearing capacity:

- 60 kN/m² pressure of fresh concrete of up to -3.00 m;
- Can be vertically stacked up to 6.00 m with the use of one joint;
- High quality film faced plywood with a thickness of 15 mm. Film weight is 240 g/m².

Cost-effective:

- Manhandled formwork panels minimize the crane use;
- High number of use cycles results in lower follow-up expenses;
- Reduction of expenses due to possibility of restoration and cleaning;
- Galvanized or powder-coated steel frames for long service life;
- High quality of concrete surface reduces finishing work to minimum.

Easy handling and planning:

- All the connectors and accessories are easily fixed in the slots and quickly tighten, thus maximizing and making forming time efficient;
- The ingeniously coordinated panel widths provide for optimal adaptation to any structure.

Safe use:

- Such accessories as lifting hooks, wall brackets, supporting struts, etc. make the system handling safer and easier.

Varimid system applications:

- Wall formwork;
- Column formwork;
- Foundation formwork.

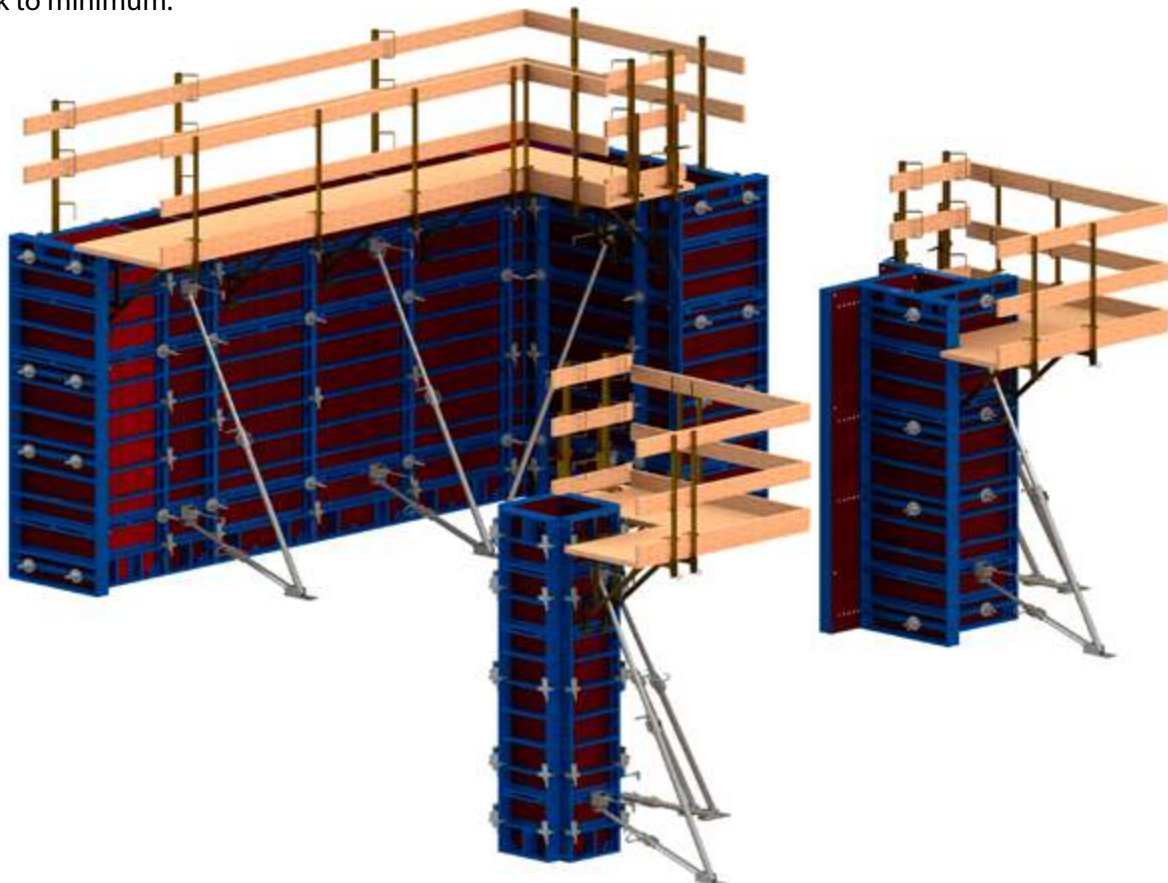



VARIMID panels

Heights and widths of the Varimid panels provide for availability of a logical and advantageous increment-grid. Small range of panel sizes makes planning easier and forming faster.

- 7 widths of panel
- 4 heights of panel

For any panel type and size there are two options of covering available.



Galvanized

Powder-coated

STANDARD PANELS

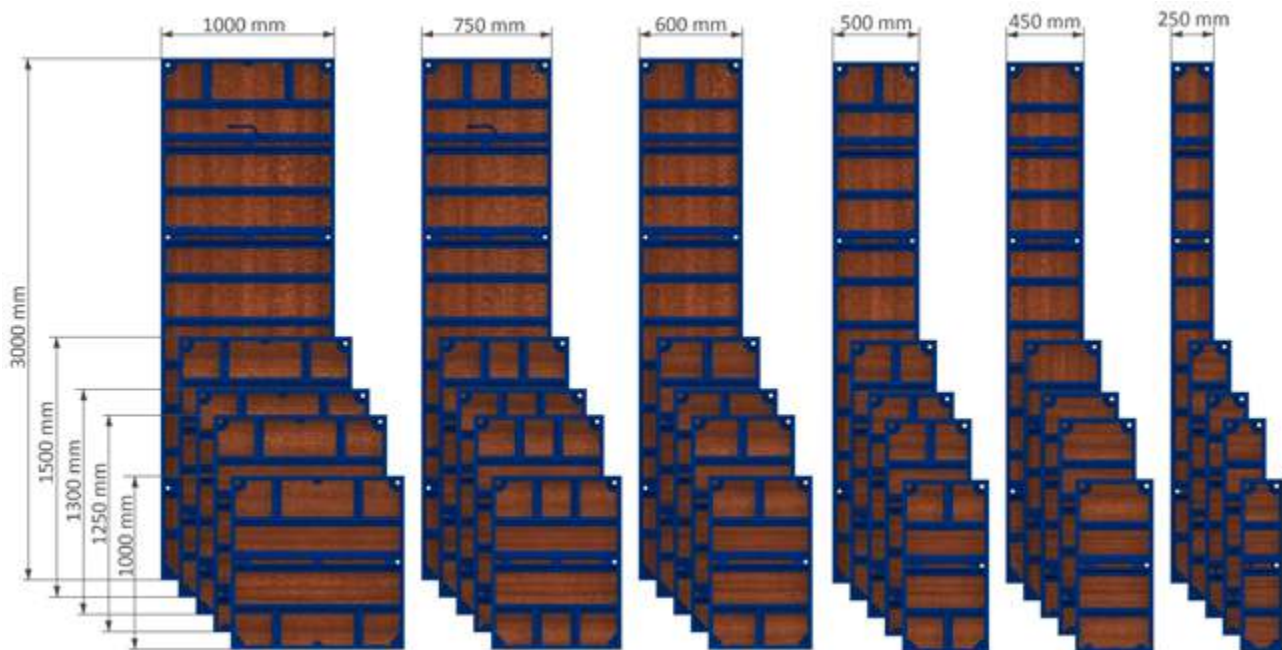

VERSATILE PANELS

Special hole pattern makes these panels particularly suitable for efficient forming of:

- Corners;
- Wall junctions;
- Stop-ends;
- Columns.

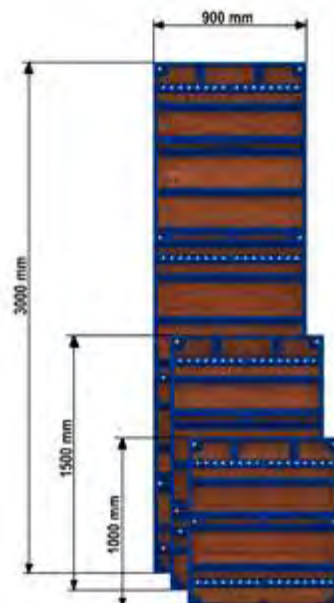

MODULE PANELS

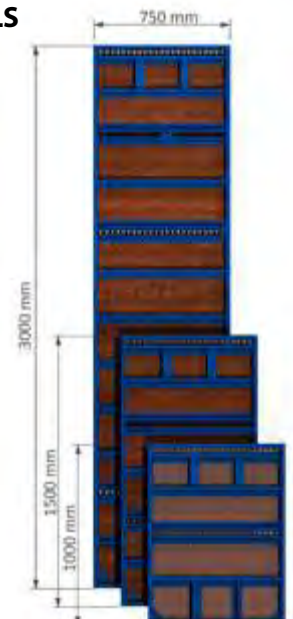

STRIPPING CORNER

The Varimid stripping corner was specially designed for the use with shaft formwork. It provides for formwork to be closed and opened in accordance with accident protection regulations, i.e. without crane, simply by operating easy-to-turn spindles with a reinforcement rod or convenient ratchet. It is then lifted and reinstalled in one piece, thus saving crane-operation time. The Varimid stripping corner is also suitable for use on pilasters and as an inside corner on wall formwork.

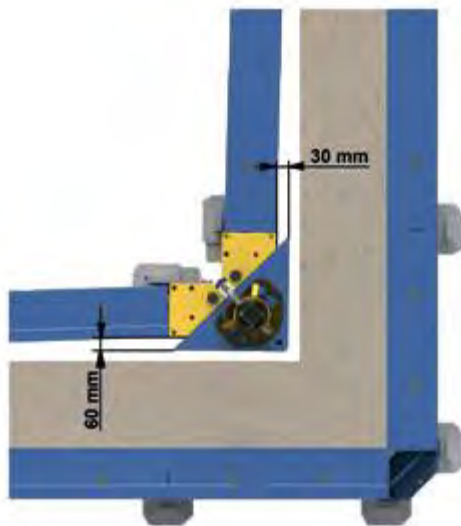

JOINING

Due to a continuous slot provided along the whole panel profile, the Varimid clamp device can be installed in any desired point, simply with a blow of the hammer. This makes assembly super-fast and no special tools required.

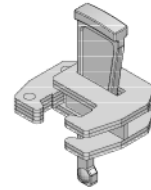





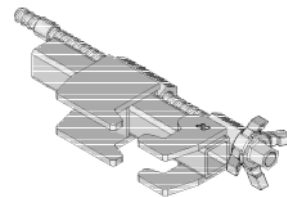









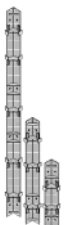









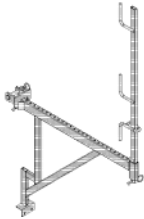





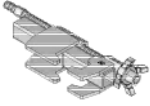

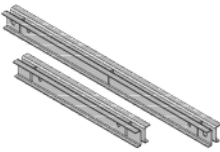



CLOSURES

Closures are intended for use in places where formwork cannot be easily stricken. It is filled with construction timber and tightened with the use of an adjustable clamp device.

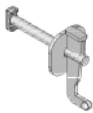











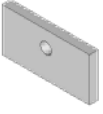

VARIMID

Item	[kg]	Article n°	Item	[kg]	Article n°				
Standard panel Varimid  Options available: xx xxx 000 - Powder coated; xx xxx 100 - Galvanized; xx xxx 200 - Hot dip galvanized; Custom size on request	1.00x3.00m	131,25	12 100 000	Internal angle Varimid  Options available: xx xxx 000 - Powder coated; xx xxx 200 - Hot dip galvanized; Custom size on request	0.25x3.00m	74,55	12 610 000		
	0.75x3.00m	107,10	12 110 000		0.25x1.50m	41,09	12 620 000		
	0.60x3.00m	85,45	12 112 000		0.25x1.00m	26,50	12 630 000		
	0.50x3.00m	80,85	12 114 000						
	0.45x3.00m	77,18	12 116 000						
	0.25x3.00m	63,95	12 118 000						
	1.00x1.50m	73,17	12 200 000						
	0.75x1.50m	59,35	12 210 000						
	0.60x1.50m	49,44	12 212 000						
	0.50x1.50m	43,76	12 214 000						
	0.45x1.50m	39,74	12 216 000						
	0.25x1.50m	28,38	12 218 000						
	1.00x1.00m	48,47	12 300 000						
	0.75x1.00m	39,70	12 310 000						
	0.60x1.00m	34,58	12 312 000						
	0.50x1.00m	29,55	12 314 000						
	0.45x1.00m	27,37	12 316 000						
0.25x1.00m	19,22	12 318 000							
Versatile panel Varimid  Options available: xx xxx 000 - Powder coated; xx xxx 100 - Galvanized; xx xxx 200 - Hot dip galvanized; Custom size on request	0.90x3.00m-V	131,25	12 102 000	Joint angle Varimid  Options available: xx xxx 000 - Powder coated; xx xxx 200 - Hot dip galvanized; Custom size on request		0.25x3.00m	99,75	12 612 000	
	0.75x3.00m-V	114,56	12 106 000		0.25x1.50m	48,71	12 622 000		
	0.90x1.50m-V	71,89	12 202 000		0.25x1.00m	34,86	12 632 000		
	0.75x1.50m-V	65,43	12 206 000						
	0.90x1.00m-V	53,70	12 302 000						
	0.75x1.00m-V	46,63	12 306 000						
Stop-end panel Varimid  Options available: xx xxx 000 - Powder coated; xx xxx 100 - Galvanized; xx xxx 200 - Hot dip galvanized; Custom size on request	0.90x3.00m-E	131,53	12 104 000	External angle Varimid  Options available: xx xxx 000 - Powder coated; xx xxx 200 - Hot dip galvanized; Custom size on request		3.00m	39,38	12 614 000	
	0.90x1.50m-E	71,88	12 204 000		1.50m	20,04	12 624 000		
	0.90x1.00m-E	53,69	12 304 000		1.00m	13,70	12 634 000		
Multipurpose panel Varimid  Options available: xx xxx 000 - Powder coated; xx xxx 100 - Galvanized; xx xxx 200 - Hot dip galvanized; Custom size on request	0.75x3.00m-M	116,87	12 108 000	Expansion block Varimid  Options available: xx xxx 000 - Powder coated; xx xxx 200 - Hot dip galvanized; Custom size on request	3.00m	54,14	12 700 000		
	0.75x1.50m-M	65,52	12 208 000		1.50m	28,60	12 702 000		
	0.75x1.00m-M	45,15	12 308 000		1.00m	20,80	12 704 000		
									
									

Item	[kg]	Article n°	Item	[kg]	Article n°
Lifting hook LH-H-0.5t Varimid 	7,61	12 718 000	Wall bracket Varimid 	12,92	12 720 000
		EN 13155 EN ISO 12100 EN 349			
Clamp device Varimid 	2,02	12 710 100	Guide rail clamp 	12,40	52 400 100
					
Adjustable clamp Varimid 	4,95	12 712 100			
					
Guide plate 	0.90 m 1.50 m	11,35 18,85	Supporting strut 250 	22,94	12 722 100
					
Corner guide plate 	0.60x0.60m	14,04	Supporting strut 340 	37,38	11 928 100
					
Contact device 		1,49	Supporting strut 540 	36,91	11 930 100
					
Stop-end tie Varimid 		1,31			
					
Connection screw 	10-16 10-25	0,63 0,79			
		11 908 100 11 910 100			

VARIMID

Item	[kg]	Article n°	Item	[kg]	Article n°	
Superplate 	15	1,22	95 200 100	Stacking angle Varimid 	0,031	12 994 400
Hexagon nut 	15	0,37	95 208 100	Stacking spacer Varimid 	0,026	12 992 400
Pressure plate 		0,86	95 210 100	Plug for holes 	0,003	12 990 400
Plastic tube 22 mm 	2.00m	0,36	99 100 400			
Plastic cone 	22	0,005	99 102 400			
Tie rod 15.0 mm 	0.50m 0.75m 1.00m 1.25m 1.50m 1.75m 2.00m 2.25m 2.50m 2.75m 3.00m 6.00m	0,80 1,20 1,60 2,00 2,40 2,80 3,20 3,60 4,00 4,40 4,80 9,60	92 050 300 92 075 300 92 100 300 92 125 300 92 150 300 92 175 300 92 200 300 92 225 300 92 250 300 92 275 300 92 300 300 92 600 300			
Clamp device Vari-right 		2,69	12 724 100			
						
Clamp device Vari-left 		2,69	12 726 100			
						



Lightweight framed formwork VARIECO

Tried and tested crane-independent manhandled framed system for foundations, walls and columns.

The lightweight framed formwork Varieco by Variant is a complete system with accessories included that delivers perfect forming performance on construction sites without crane use. Sufficient load-bearing capacity and long service life of the Varieco system makes it a cost-effective solution.

Sufficient load-bearing capacity:

- 60 kN/m² pressure of fresh concrete of up to 3.00 m;
- 40 kN/m² pressure of fresh concrete of up to 4.50 m;
- Can be vertically stacked up to 4.50 m with use of one joint;
- High quality film faced plywood with thickness of 15 mm. Film weight is 240 g/m².

Cost-effective:

- Manhandled formwork panels reduce the crane use to minimum;
- High number of use cycles results in lower follow-up expenses;
- Reduction of expenses due to possibility of restoration and cleaning;
- Galvanized or powder-coated steel frames for long service life;
- High quality of concrete surface reduces finishing work to minimum.

Easy handling and planning:

- All the connectors and accessories are easily fixed in the slots and quickly tighten, thus maximizing and making forming time efficient;
- The ingeniously coordinated panel widths provide for optimal adaptation to any structure.

Safe use:

- Such accessories as - supporting struts, wall brackets, etc. make the system handling safer and easier.

Varieco system applications:

- Wall formwork;
- Column formwork;
- Foundation formwork.



Heights and widths of the Varieco panels provide for availability of a logical and advantageous increment-grid. Small range of panel sizes makes planning easier and forming faster.

- 5 widths of panel
- 4 heights of panel

For any panel type and size there are two options of covering available.



Galvanized

Powder-coated

STANDARD PANELS

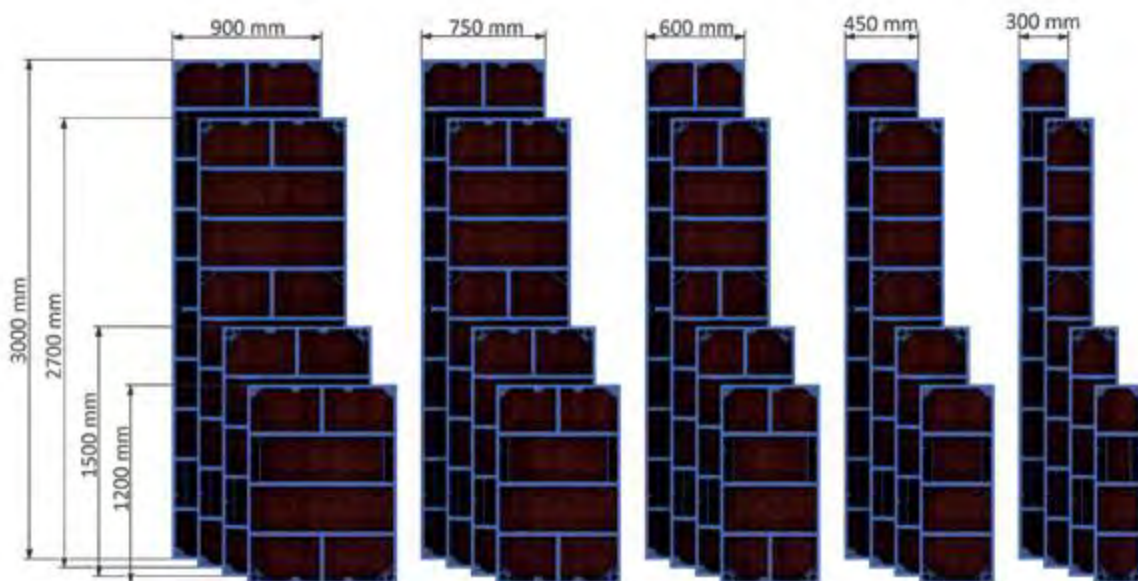

VERSATILE PANELS

Special hole pattern makes these panels particularly suitable for efficient forming of:

- Corners;
- Wall junctions;
- Stop-ends;
- Columns.

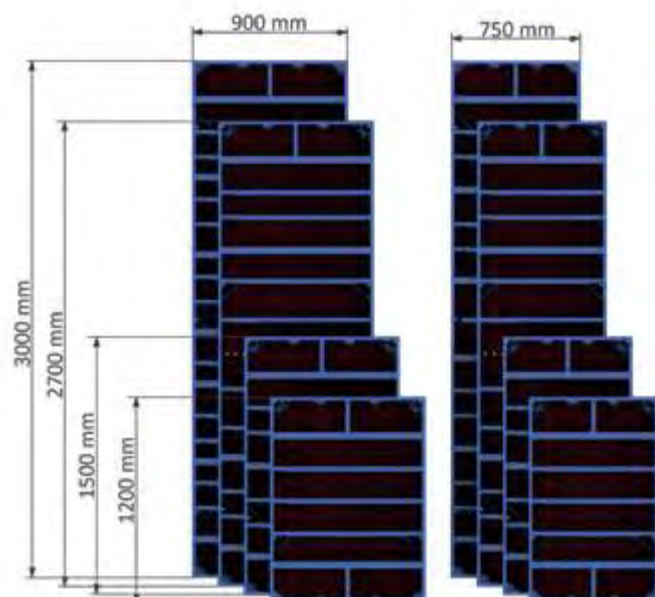

VARIECO panel connection

JOINING

Due to a continuous slot provided along the whole panel profile, the Varieco clamp device can be installed in any desired point, simply with a blow of the hammer. This makes assembly super-fast and no special tools required.

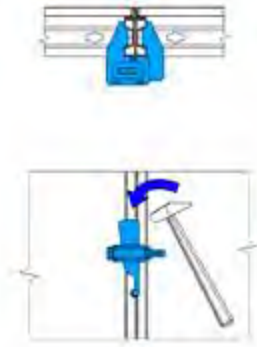
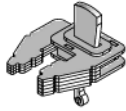





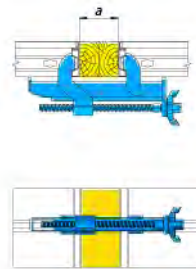
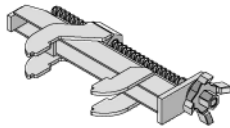



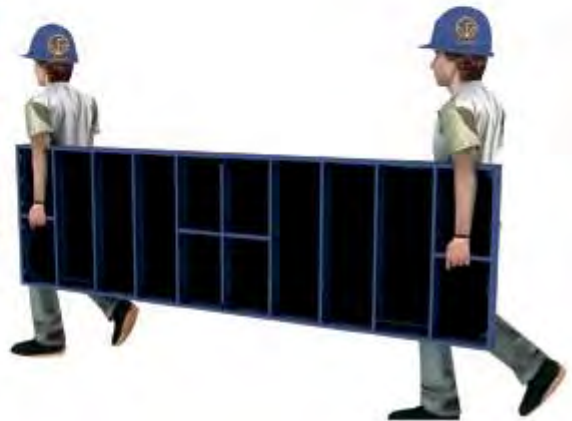



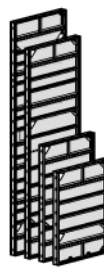

CLOSURES

Closures are intended for use in places where formwork cannot be easily stricken. It is filled with construction timber and tightened with the use of an adjustable clamp device.

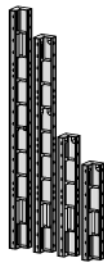
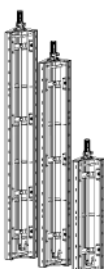









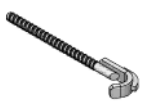

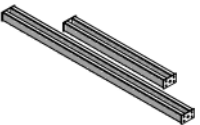

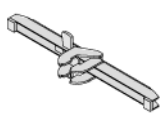

a... max. 15 cm

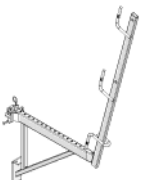

Item	[kg]	Article n°	Item	[kg]	Article n°		
Standard panel Varieco  Options available: xx xxx 000 - Powder coated; xx xxx 200 - Hot dip galvanized; Custom size on request	0.90x3.00m	85,58	16 102 000	External angle Varieco  Options available: xx xxx 000 - Powder coated; xx xxx 200 - Hot dip galvanized; Custom size on request	3.00m	20,80	16 614 000
	0.75x3.00m	75,39	16 106 000		2.70m	19,02	16 624 000
	0.60x3.00m	65,10	16 108 000		1.50m	10,35	16 634 000
	0.45x3.00m	53,66	16 110 000		1.20m	8,68	16 644 000
	0.30x3.00m	43,47	16 112 000		<div style="text-align: center;">  </div>		
	0.90x2.70m	77,18	16 202 000				
	0.75x2.70m	67,94	16 206 000				
	0.60x2.70m	58,59	16 208 000				
	0.45x2.70m	48,41	16 210 000				
	0.30x2.70m	39,17	16 212 000				
	0.90x1.50m	45,68	16 302 000				
	0.75x1.50m	40,32	16 306 000				
	0.60x1.50m	34,86	16 308 000				
	0.45x1.50m	28,46	16 310 000				
	0.30x1.50m	23,10	16 312 000				
	0.90x1.20m	37,59	16 402 000				
	0.75x1.20m	33,18	16 406 000				
	0.60x1.20m	28,67	16 408 000				
	0.45x1.20m	23,52	16 410 000				
	0.30x1.20m	19,11	16 412 000				
<div style="border: 1px solid black; padding: 2px;">  </div>							
Versatile panel Varieco  Options available: xx xxx 000 - Powder coated; xx xxx 200 - Hot dip galvanized; Custom size on request	0.90x3.00m	117,42	16 100 000	Joint angle Varieco  Options available: xx xxx 000 - Powder coated; xx xxx 200 - Hot dip galvanized; Custom size on request	0.20x1.50m	39,94	16 632 000
	0.75x3.00m	95,24	16 104 000		0.20x1.20m	33,04	16 642 000
<div style="border: 1px solid black; padding: 2px;">  </div>			<div style="border: 1px solid black; padding: 2px;">  </div>				
Internal angle Varieco  Options available: xx xxx 000 - Powder coated; xx xxx 200 - Hot dip galvanized; Custom size on request	0.20x3.00m	61,43	16 610 000	Stripping corner Varieco  Options available: xx xxx 000 - Powder coated; xx xxx 200 - Hot dip galvanized; Custom size on request	0.30x3.00m	151,83	16 616 000
	0.20x2.70m	54,93	16 620 000		0.30x2.70m	135,14	16 626 000
	0.20x1.50m	32,16	16 630 000		0.30x1.50m	82,01	16 636 000
	0.20x1.20m	26,62	16 640 000		<div style="border: 1px solid black; padding: 2px;">  </div>		
<div style="border: 1px solid black; padding: 2px;">  </div>							
Adjustable clamp Varieco 	<div style="border: 1px solid black; padding: 2px;">  </div>			<div style="border: 1px solid black; padding: 2px;">  </div>			

VARIECO

Item	[kg]	Article n°	Item	[kg]	Article n°	
Profile connector 5-18 Varieco 	0,80	16 906 100	Supporting strut 260 Varieco 	16,62	16 970 100	
Connection screw 5-12 Varieco 	0,48	16 908 100				
Guide plate Varieco 	0.70m 1.25m	4,20 6,98	Supporting strut 340 Varieco 	33,50	16 972 100	
Contact device Varieco 	1,20	16 914 100				
Clip Varieco 	0,30	16 916 100	Strut connection profile Varieco 	11,03	16 922 000	
Aligning clamp Varieco 	3,26	16 918 100	Superplate 	15	1,22	95 200 100
Profile adapter Varieco to Varimax 	0,62	16 920 100	Plastic tube 22 mm 	2.00m	0,36	99 100 400
Lifting hook LH-SL-0.5t Varieco 	7,67	16 950 000	Plastic cone 	22	0,005	99 102 400
Wall bracket Varieco 	8,73	16 960 100	Tie rod 15.0 mm 	0.50m 0.75m 1.00m 1.25m 1.50m 1.75m 2.00m	0,80 1,20 1,60 2,00 2,40 2,80 3,20	92 050 300 92 075 300 92 100 300 92 125 300 92 150 300 92 175 300 92 200 300

VARIANT

**QUALITY IS
BASIS OF SAFETY**

Super-lightweight framed formwork HANDI

The universal super-lightweight formwork to operate without crane.

Handi is a lightweight framed formwork system specially designed for quick and cost-saving construction. Owing to lightweight panels the forming can be done manually with ease. Consequently, the Handi system suits best for foundations forming and execution of small aboveground and underground concreting works without or with the limited crane use and in case it complicated to use heavy framed formwork systems (e.g. Varimax system). In addition, these systems showed their efficiency in small projects including construction of villas, private houses, residential compounds, etc.

Load-bearing capacity:

- 35 kN/m² pressure of fresh concrete;
- High quality film faced plywood with thickness of 15 mm. Film weight is 240 g/m².

Cost-effective:

- Universal application of the Handi system will give you an opportunity to use one system for a range of different tasks;
- Reduction of expenses due to minimization of crane use;
- High number of use cycles results in lower follow-up expenses;
- Reduction of expenses due to possibility of restoration and cleaning;
- Galvanized or powder-coated steel frames for long service life;
- High quality of concrete surface reduces finishing work to minimum.

Handi system applications:

- Wall formwork;
- Column formwork;
- Foundation formwork.

Easy to use:

- Grid of standard panel sizes provides for easier planning and forming;
- All the connectors and accessories are easily fixed in the slots and quickly tighten, thus maximizing and making forming time efficient;
- System ergonomics ensures fast and save assembly.

Safe use:

- Such accessories as lifting hooks, wall brackets, supporting struts, etc. make the system handling safer and easier.

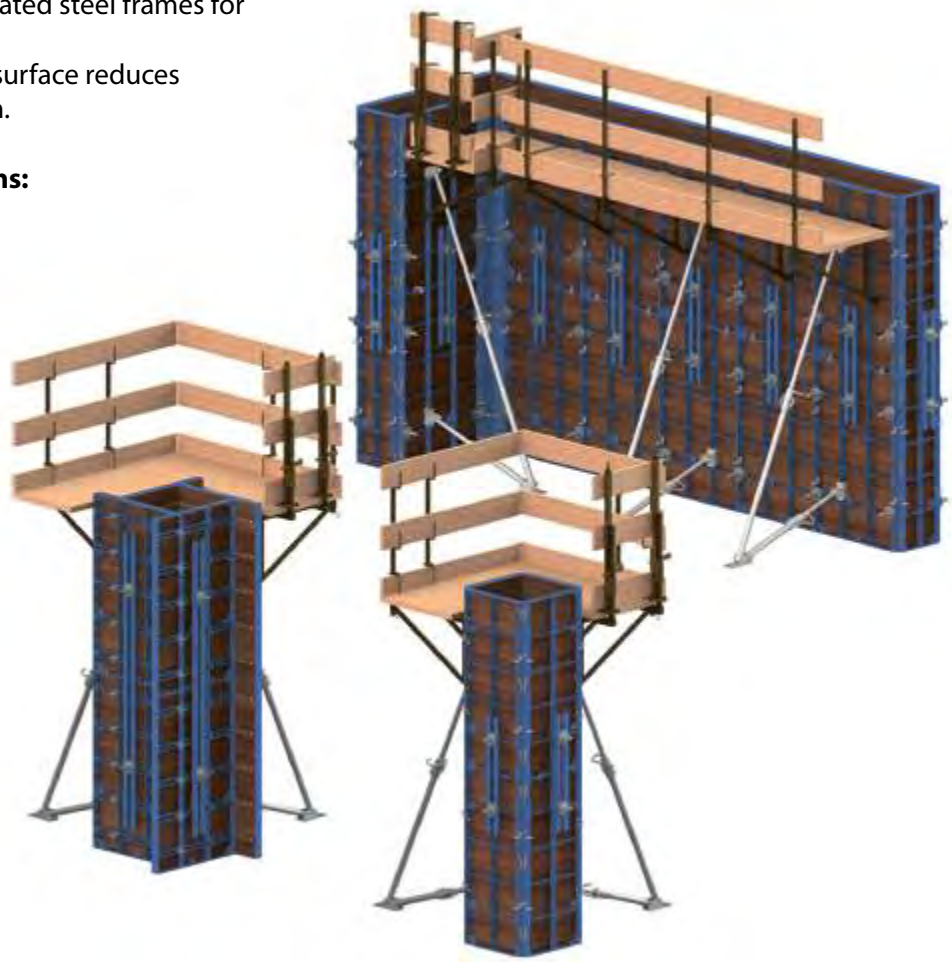



HANDI panels

Heights and widths of the Handi panels provide for availability of a logical and advantageous increment-grid. Small range of panel sizes makes planning easier and forming faster.

- 7 widths of panel
- 3 heights of panel

For any type and size of the panel two options of covering are available.



Galvanized

Powder-coated

STANDARD PANELS



VERSATILE PANELS

Special hole pattern makes these panels particularly suitable for efficient forming of:

- Corners;
- Wall junctions;
- Columns.

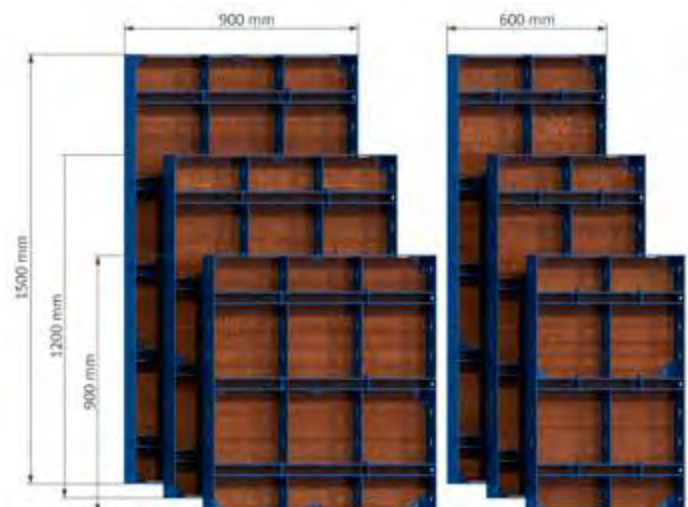

CLIP

Binding clip is used to connect Handi panels. Install the clip into the slot and turn by 90° and the components will be firmly fixed.



BINDING CLIP

Binding clips can also be used to connect Handi panels.







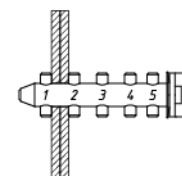
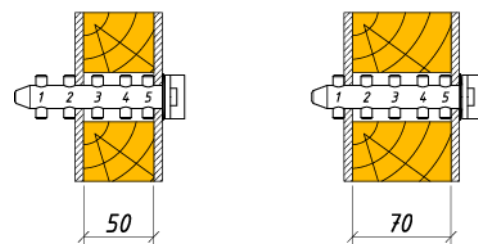



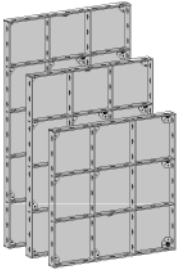
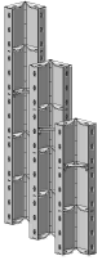
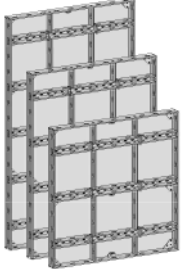



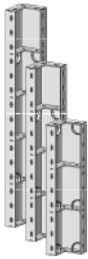





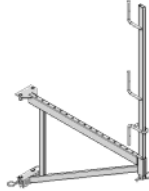

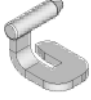
5-PIN CLAMP FOR COMPENSATION OF LINEAR EXTENSIONS

In case compensation of linear extensions (1-5 cm; 7 cm) between the panels is needed, just connect panels with a 5-pin clamp. Installation procedure of the 5-pin clamp is identical to installation of the clip.









HANDI

Item	[kg]	Article n°	Item	[kg]	Article n°		
Standard panel Handi  Options available: xx xxx 000 - Powder coated; xx xxx 100 - Galvanized; xx xxx 200 - Hot dip galvanized; Custom size on request	0.90x1.50m	54,10	13 112 000	Joint angle Handi  Options available: xx xxx 000 - Powder coated; xx xxx 200 - Hot dip galvanized; Custom size on request	0.20x1.50m	38,06	13 412 000
	0.60x1.50m	37,95	13 116 000		0.20x1.20m	29,19	13 422 000
	0.50x1.50m	34,15	13 118 000		0.20x0.90m	22,17	13 432 000
	0.40x1.50m	30,35	13 120 000		ISO 3834		
	0.30x1.50m	22,48	13 122 000				
	0.25x1.50m	20,32	13 124 000				
	0.20x1.50m	18,51	13 126 000				
	0.15x1.50m	16,57	13 128 000				
	0.90x1.20m	44,17	13 212 000				
	0.60x1.20m	30,96	13 216 000				
	0.50x1.20m	27,72	13 218 000				
	0.40x1.20m	24,60	13 220 000				
	0.30x1.20m	18,24	13 222 000				
	0.25x1.20m	16,52	13 224 000				
	0.20x1.20m	15,00	13 226 000				
	0.15x1.20m	13,44	13 228 000				
	0.90x0.90m	34,59	13 312 000				
	0.60x0.90m	23,98	13 316 000				
	0.50x0.90m	21,79	13 318 000				
	0.40x0.90m	19,02	13 320 000				
0.30x0.90m	14,23	13 322 000					
0.25x0.90m	12,78	13 324 000					
0.20x0.90m	11,62	13 326 000					
0.15x0.90m	10,37	13 328 000					
ISO 3834							
Versatile panel Handi  Options available: xx xxx 000 - Powder coated; xx xxx 100 - Galvanized; xx xxx 200 - Hot dip galvanized; Custom size on request	0.90x1.50m-V	64,65	13 110 000	External angle Handi  Options available: xx xxx 000 - Powder coated; xx xxx 200 - Hot dip galvanized; Custom size on request	1.50m	10,50	13 414 000
	0.60x1.50m-V	45,59	13 114 000		1.20m	8,42	13 424 000
	0.90x1.20m-V	52,51	13 210 000		0.90m	6,34	13 434 000
	0.60x1.20m-V	36,93	13 214 000		0.60m	4,27	13 444 000
	0.90x0.90m-V	41,04	13 310 000		ISO 3834		
	0.60x0.90m-V	28,77	13 314 000				
ISO 3834							
Expansion block Handi  Options available: xx xxx 000 - Powder coated; xx xxx 200 - Hot dip galvanized; Custom size on request				Waling Handi  Options available: xx xxx 000 - Powder coated; xx xxx 200 - Hot dip galvanized; Custom size on request	1.50m	14,93	13 610 000
					1.20m	11,95	13 620 000
					0.90m	9,07	13 630 000
					0.60m	5,96	13 640 000
					ISO 3834		
Internal angle Handi  Options available: xx xxx 000 - Powder coated; xx xxx 200 - Hot dip galvanized; Custom size on request	0.20x1.50m	35,64	13 410 000	Expansion block Handi  Options available: xx xxx 000 - Powder coated; xx xxx 200 - Hot dip galvanized; Custom size on request	0.50m	4,67	13 505 000
	0.20x1.50m	28,71	13 420 000		1.00m	9,37	13 510 000
	0.20x0.90m	21,07	13 430 000		1.50m	13,86	13 515 000
ISO 3834				2.00m	18,46	13 520 000	
				2.50m	23,05	13 525 000	
				3.00m	27,57	13 530 000	
				ISO 3834			
Lifting hook Handi  Options available: xx xxx 000 - Powder coated; xx xxx 200 - Hot dip galvanized; Custom size on request				Lifting hook Handi  Options available: xx xxx 000 - Powder coated; xx xxx 200 - Hot dip galvanized; Custom size on request	2,89	13 706 100	
					ISO 3834		

Item	[kg]	Article n°	Item	[kg]	Article n°
Clip Handi 	0,18	13 710 100	Wall bracket Handi 	11,98	13 700 100
5-pin clamp Handi 	0,27	13 712 100	Guide rail clamp 	12,40	52 400 100
Binding clip Handi 	0,27	13 714 100		Tension screw Handi 	0,36
Connection screw 5-10 	0,42	13 718 100	Supporting strut 250 Handi 	22,94	13 702 100
Stop-end plate Handi 6x75x750mm 	2,48	13 716 000	Supporting strut 340 Handi 	33,29	13 704 100
Foundation clamp Handi 	1,64	13 722 100	Superplate 15 	1,22	95 200 100
Perforated tape 50x2 mm 	1.00m 0,68 1.50m 1,02 2.00m 1,36 2.50m 1,70 3.00m 2,04	96 110 300 96 115 300 96 120 300 96 125 300 96 130 300	Star-shaped nut 15 	0,40	95 206 100

HANDI

Item		[kg]	Article n°	Item	[kg]	Article n°
Washer		0,10	13 720 100			
						
Plastic tube 22 mm	2.00m	0,36	99 100 400			
						
Plastic cone 22 mm		0,005	99 102 400			
						
Tie rod 15.0 mm	0.50m 0.75m 1.00m 1.25m 1.50m 1.75m 2.00m 2.25m 2.50m 2.75m 3.00m	0,80 1,20 1,60 2,00 2,40 2,80 3,20 3,60 4,00 4,40 4,80	92 050 300 92 075 300 92 100 300 92 125 300 92 150 300 92 175 300 92 200 300 92 225 300 92 250 300 92 275 300 92 300 300			
						
Handle Handi		0,84	13 724 100			
						
Stacking angle Handi		0,03	13 990 400			
						
Plug for holes		0,003	12 990 400			
						

Variant your best partner in construction formwork

variant-factory.eu

Large-area formwork VERTEX 60

System for large-area walls forming useful both in practical and economic aspects.

It is an easily adaptable system, meeting all the architectural requirements for concrete design. Vertex 60 may be used in different projects and construction sites. It ranges from simple straight walls, complicated column cross-section to residential and high-rise construction including construction of the bridges. It can also be used as formwork shutters for single sided or climbing systems. The standard components of the system such as steel walings, H20 beams and flange clamps can be assembled in formwork and customized for a particular project.

Adaptable load-bearing capacity:

- Due to its adaptability Vertex 60 can be assembled and customized to withstand almost any pressure of fresh concrete (recommended range is from 30 up to 70 kN/m²);
- The most cost-effective in terms of formwork price and pace of forming is 40 kN/m² of permitted pressure of fresh concrete.

Cost-effective:

- Large-areas of concrete surface can be easily cast;
- High number of use cycles results in lower follow-up expenses;
- Reduction of expenses by means of system adaptability;
- High quality of concrete surface reduces finishing work to minimum;
- Project-specific adaptation possible as it can be faced with any type of form-ply.

Easy handling and planning:

- All the connectors and accessories are easily fixed in the slots and quickly tighten, thus maximizing and making forming time efficient;
- Load-bearing capacity of the system can be adjusted by means of H20 beams and steel walings;
- Any architectural requirements for concrete design can be met owing to this system adaptability.

Safe use:

- Such accessories as lifting hooks, wall brackets, supporting struts, etc. make the system handling safer and easier.

Vertex 60 system applications:

- Large area wall formwork;
- Column formwork;
- Single sided systems;
- Bridge construction;
- Climbing systems.

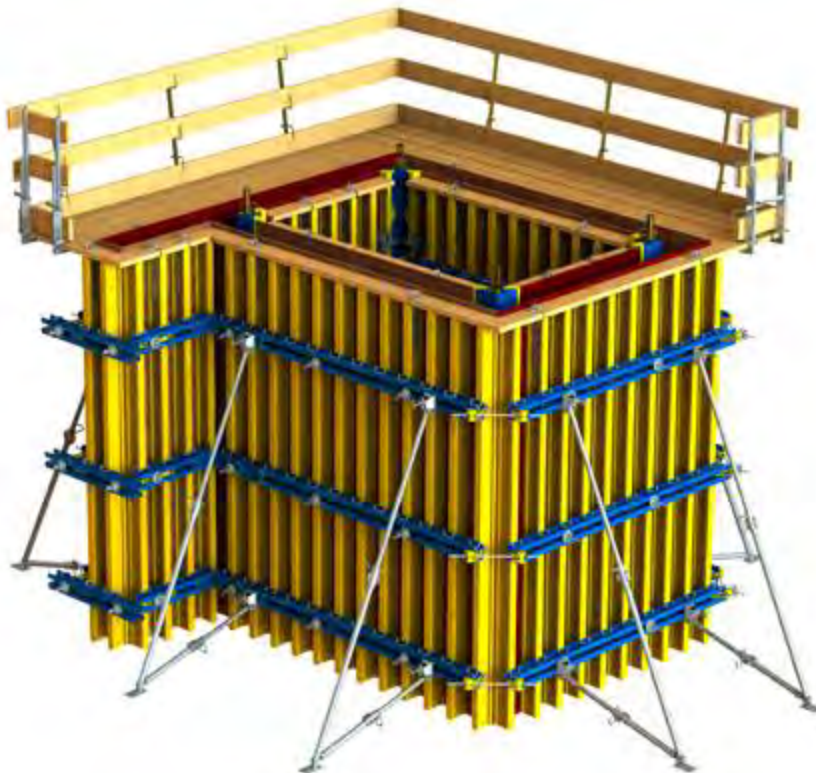



VERTEX 60 panels

SIZES

The size of a panel assembled depends on:

- Length of steel waling used – defines possible width of Vertex 60 panel.

Variant provides a wide range of waling from 0.5 m to 6.0 m in a 250 mm grid.

- Length of H20 beams – defines possible height of Vertex 60 panel.

Variant provides a wide range of H20 beams from 1.25 m to 5.9 m.

Consequently the smallest panel possible is 0.5 m wide and 1.25 m high and the biggest one is 6.0 m wide and 6.0 m high.

LOAD-BEARING ADAPTABILITY

Depending on the concrete pressure required, the Variant H20 beams and walings are spaced closer to each other or further apart. Thus ensuring optimal formwork design and great economy of materials. For more information on structural design of Vertex 60 elements – see "User manual".



e.g. concrete pressure
of **30 kN/m²**



e.g. concrete pressure
of **70 kN/m²**



Vertex 60 elements can be assembled **in heights of up to 6.0 m.**

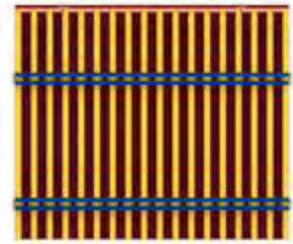

Vertex 60 elements can be assembled **in width of up to 6.0 m.**

STACKING

Vertex 60 panels can be assembled in a gang-form by means of vertical staking. A panel connection with a stacking plate has sufficient flexural stiffness to allow panel unit of up to 12 m high to be lifted as one piece.

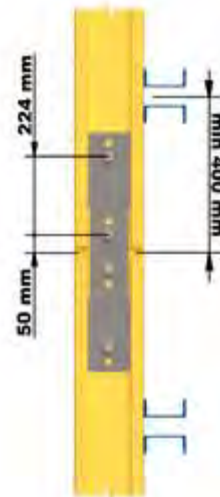

Maximum height of a gang-form is **up to 12 m.**

VERTEX 60 inter-panel connection

JOINING BY MEANS OF CONNECTING PLATE

Connecting plate and four pins with spring cotters are required for standard inter-panel connection.

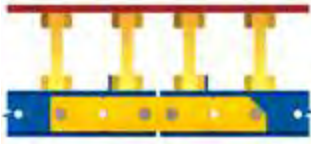

JOINING BY MEANS OF ADJUSTABLE CONNECTING PLATE AND JOINT PLATE

When there is space between panels, an adjustable connecting plate with pins and spring cotters are used. Joint plate is required for easier stripping.

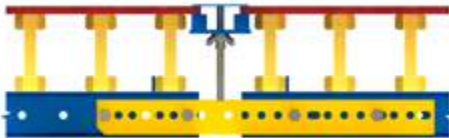

VERTEX 60 stop-end and corners forming

STOP-END FORMING

The Vertex 60 is a complete formwork system. As such, it offers practical solutions for stop-end formwork. Tie rods are screwed into an anchoring plate, and the stop-end element spacing is adjusted with superplate.

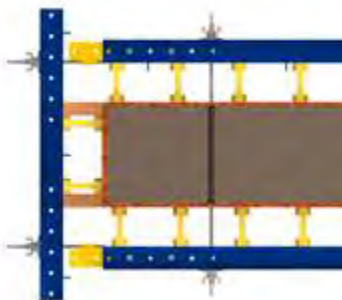

CORNERS

In case a form-ply is nailed to the end face of standard elements, they are considered to be corner elements. The concrete pressure on the end face is released with the help of edge beam reinforcements.

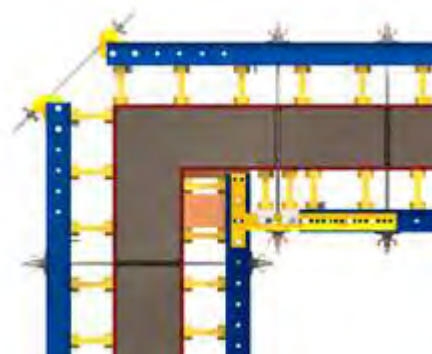

VERTEX 60 stop-end and corners forming

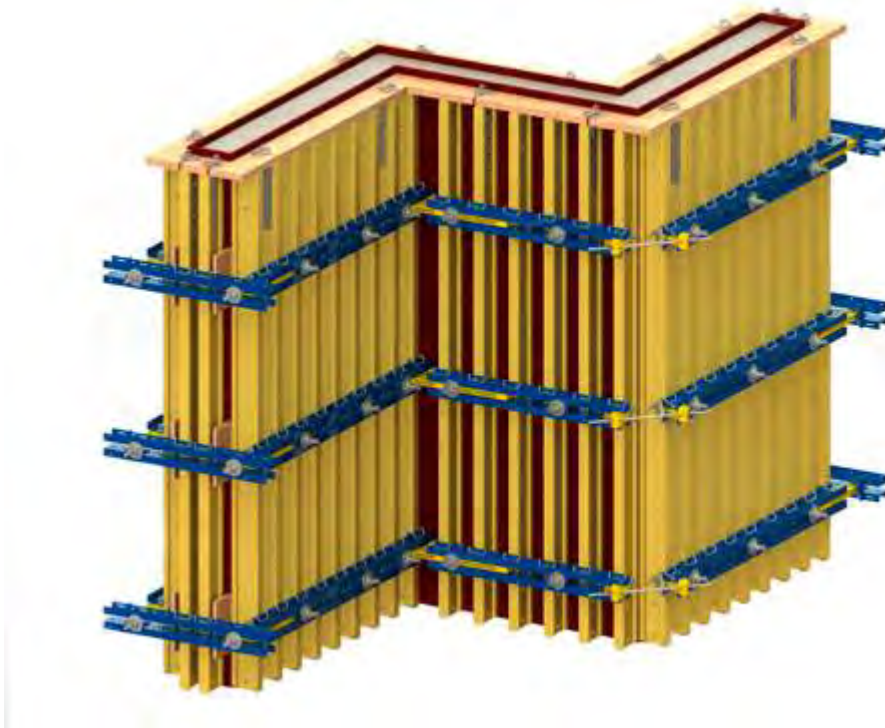

COMBINING WITH DIFFERENT FORMWORK SYSTEMS

Vertex 60 timber-beam formwork can be combined with the following formwork systems:

- Varimax framed formwork





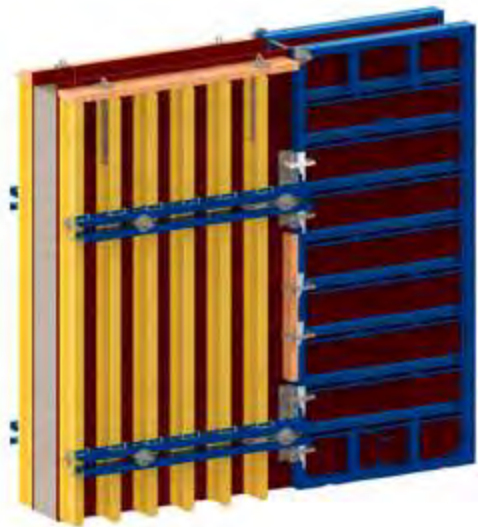
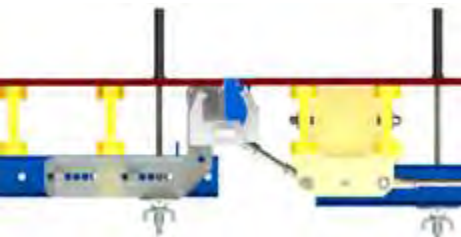



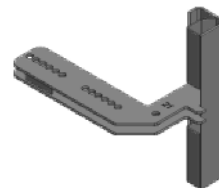

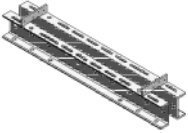













- Ringform circular formwork















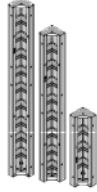





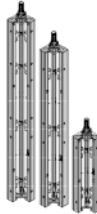

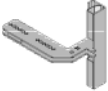









The Transition plate of 18 mm or 21 mm is required for these combinations.





Item	[kg]	Article n°	Item	[kg]	Article n°	
Waling 12 	0.50m	10,92	21 050 000	6,41 	23 200 100	
	0.75m	15,96	21 075 000			
	1.00m	21,00	21 100 000			
	1.25m	26,25	21 125 000			
	1.50m	31,82	21 150 000			
	1.75m	37,07	21 175 000			
	2.00m	42,32	21 200 000			
	2.25m	47,46	21 225 000			
	2.50m	52,71	21 250 000			
	2.75m	58,28	21 275 000			
	3.00m	63,53	21 300 000			
	3.25m	69,00	21 325 000			
	3.50m	75,33	21 350 000			
	3.75m	80,21	21 375 000			
	4.00m	85,47	21 400 000			
	4.50m	95,99	21 450 000			
5.00m	106,37	21 500 000				
6.00m	128,63	21 600 000				
						
Waling 10 	0.50m	10,92	22 050 000	60 110	0,07 0,09	
	0.75m	16,17	22 075 000			
	1.00m	21,42	22 100 000			
	1.25m	26,67	22 125 000			
	1.50m	32,45	22 150 000			
	1.75m	37,70	22 175 000			
	2.00m	41,00	22 200 000			
	2.25m	48,30	22 225 000			
	2.50m	53,55	22 250 000			
	2.75m	59,22	22 275 000			
	3.00m	64,48	22 300 000			
	3.25m	70,04	22 325 000			
	3.50m	76,34	22 350 000			
	3.75m	81,27	22 375 000			
	4.00m	86,94	22 400 000			
						
Joint plate Vertex 	3.00m	42,85	23 104 000	12 10	1,38 1,27	
	4.00m	55,35	23 106 000			
						
Stripping plate Vertex 	3.00m	71,93	23 108 000	0,39	23 400 100	
	4.00m	79,80	23 110 000			
						
Corner waling Vertex 	10	24,17	23 102 000	0,05	23 402 100	
	12	23,81	23 100 000			
						
Lifting hook Vertex 	8,82	23 202 100	8,82	1,16	23 300 100	
						
	0,24	23 306 100				
			Beam screw Vertex W 			
				Beam clamp Vertex 	12 10	1,38 1,27
	0,39	23 400 100				
			Spring cotter 			
				Connecting plate Vertex 	6,47	23 404 000
	9,69	23 406 000				
						

VERTEX 60

Item	[kg]	Article n°	Item	[kg]	Article n°
Anchoring plate Vertex 	7,17	23 408 100	Clamp device Varimax 	3,90	11 902 100
Half splice plate Vertex 	5,64	23 410 000	Adjustable clamp Varimax 	6,00	11 904 100
Shaft corner plate Vertex 	11,87	23 412 000	Internal angle Varimax 	0.30x3.30m 121,80 0.30x3.00m 98,70 0.30x2.85m 108,47 0.30x2.70m 103,49 0.30x1.35m 51,90	11 710 000 11 720 000 11 730 000 11 740 000 11 750 000
Column corner plate Vertex 	13,34	23 414 000	Options available: xx xxx 000 - Powder coated; xx xxx 200 - Hot dip galvanized; Custom size on request		
Shaft waling squaring plate 	9,18	23 416 000	Joint angle internal Varimax 	0.30x3.30m 141,23 0.30x3.00m 129,15 0.30x2.85m 120,44 0.30x2.70m 116,55 0.30x1.35m 61,36	11 712 000 11 712 000 11 732 000 11 742 000 11 752 000
Corner tie bracket Vertex 	4,46	23 418 000	Options available: xx xxx 000 - Powder coated; xx xxx 200 - Hot dip galvanized; Custom size on request		
Corner hinge plate Vertex 	18,43	23 420 100	Stripping corner Varimax 	0.30x3.30m 207,90 0.30x3.00m 190,30 0.30x2.85m 176,20 0.30x2.70m 168,70 0.30x1.35m 97,65	11 718 000 11 728 000 11 738 000 11 748 000 11 758 000
Corner spindle Vertex 	20,10	23 422 100	Options available: xx xxx 000 - Powder coated; xx xxx 200 - Hot dip galvanized; Custom size on request		
Transition plate 	12/18 18,70 12/21 19,05 10/18 17,90 10/21 18,25	23 500 100 23 502 100 23 504 100 23 506 100	Stripping spindle Varimax 	3,71	11 942 100

Item	[kg]	Article n°	Item	[kg]	Article n°
Wall bracket H20 	11,46 ISO 3834	23 700 100	Adjustable plumbing strut 	3,48 ISO 3834	11 932 100
Guide rail clamp 	12,40 ISO 3834	52 400 100	Spindle head 	3,48	11 932 100
Handrail post 	12,85 ISO 3834	52 402 100	Spindle element without end-hinge 	36,62	11 934 000
Spindle strut T7 	1.26-1.89m 23,26 1.42-2.05m 24,29 1.92-2.55m 27,56 2.42-3.05m 33,41 2.97-3.60m 36,89 ISO 3834	23 800 100 23 802 100 23 804 100 23 806 100 23 808 100	Extension strut 3.70 m 	78,75	11 936 000
			Extension strut 2.40 m 	54,13	11 938 000
			Spindle element with end-hinge 	43,81	11 940 000
			Rafter plates 	right 0,09 left 0,09	52 306 100 52 308 100
Supporting strut 340 	37,38 ISO 3834	11 928 100	Superplate 	15 1,22	95 200 100
			Wing nut 	15 0,38	95 204 100
Supporting strut 540 	56,91 ISO 3834	11 930 100	Star-shaped nut 	15 0,40	95 206 100
			Plastic tube 	2.00m 0,36	99 100 400

VERTEX 60

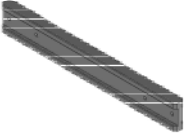
Item		[kg]	Article n°	Item	[kg]	Article n°
Plastic cone 22 mm 		0,005	99 102 400			
Tie rod 15.0 mm 	0.50m	0,80	92 050 300			
	0.75m	1,20	92 075 300			
	1.00m	1,60	92 100 300			
	1.25m	2,00	92 125 300			
	1.50m	2,40	92 150 300			
	1.75m	2,80	92 175 300			
	2.00m	3,20	92 200 300			
	2.25m	3,60	92 225 300			
	2.50m	4,00	92 250 300			
	2.75m	4,40	92 275 300			
	3.00m	4,80	92 300 300			
	6.00m	14,40	92 600 300			
	H20 beam 	1.45m	7,25	91 145 500		
1.80m		9,00	91 180 500			
1.95m		9,75	91 195 500			
2.15m		10,75	91 215 500			
2.45m		12,25	91 245 500			
2.65m		13,25	91 265 500			
2.90m		14,50	91 290 500			
3.30m		16,50	91 330 500			
3.60m		18,00	91 360 500			
3.90m		19,50	91 390 500			
4.50m		22,50	91 450 500			
4.90m		24,50	91 490 500			
5.90m	29,50	91 590 500				

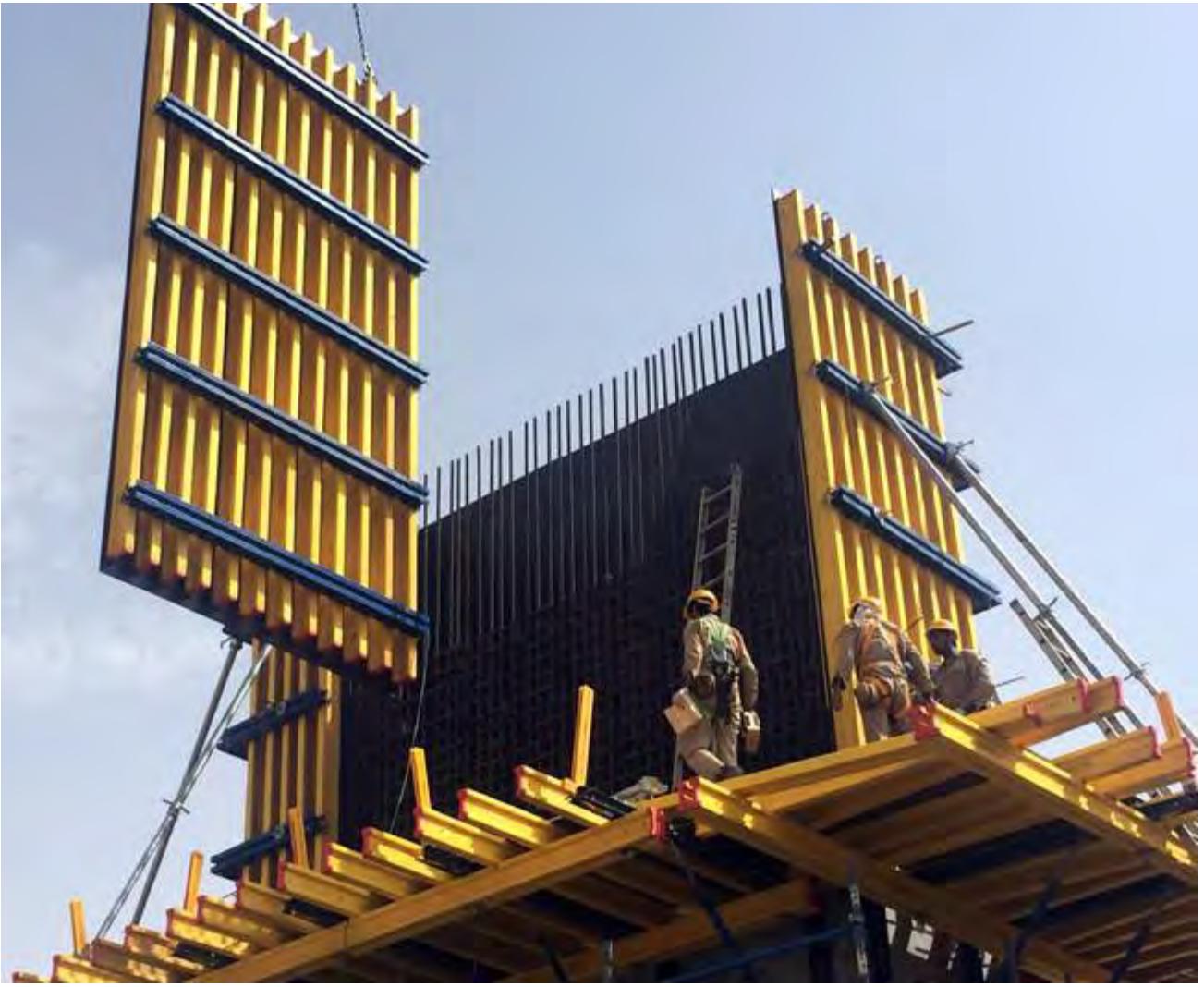

Adjustable circular formwork RINGFORM

Circular formwork for curved walls forming with an infinite radius range starting from 3.5 m.

The circular formwork Ringform by Variant is a practical system for smooth and curved wall forming. Only 6 types of elements are used including 3 sizes 1.2 / 2.4 / 3.0 m high and 2 widths, 2.4 m is used for inner part of the wall and 2.5 m – for outer one. The required radius is easily achieved with the help of adjustable spindles.

Load-bearing capacity:

- Permitted pressure of fresh concrete is 50 kN/m²;
- High quality film faced plywood with a thickness of 21 mm. Film weight is 240 g/m².

Easy to use:

- A range of only 6 standard panels provides for easier planning and forming process;
- All the connectors and accessories are easily fixed in the slots and quickly tighten, thus maximizing and making forming time efficient;
- There is no need for making extra holes in plywood. The same anchor hole is used for the whole project;
- It can be easily connected to the framed formwork Varimax;
- Radii can be continuously adjusted starting with 3.5 m simply by turning spindles.

Cost-effective:

- The system elements are pre-assembled and ready for use simply by choosing the desired radius with adjusting spindles;

- Installation of pre-assembled units reduces crane use to minimum;
- Smaller quantities are needed as it easily adapts to any layout;
- High number of use cycles results in lower follow-up expenses;
- Reduction of expenses due to possibility of restoration and cleaning;
- High quality of concrete surface minimizes finishing work.

Safe use:

- Such accessories as bracing platforms, bracing struts, etc. make the system handling safer and easier.

Quick work execution:

- Radii are easily set just by means of spindle turning;
- It can be readily combined with Varimax, Vertex 60 systems;
- There is only one type connection device (adjustable clamp).





RINGFORM panels

PANELS HEIGHT

The panels of adjustable circular formwork are of 3 heights including 1.2 m, 2.4 m, 3.0 m and this provides for their good range in terms of size. By means of vertical panel stacking their optimal height can be chosen.

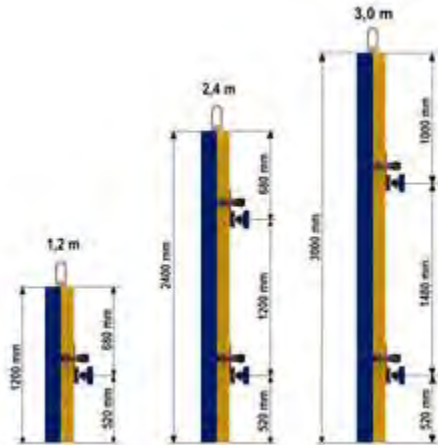

- 2 widths of panel
- 3 heights of panel

ADJUSTMENT

- One should use a template to adjust an element.
- Make sure that you turn each spindle exactly in the same manner as those placed above and below.
- Check the radius with one in the template before every pour.

Process the spindles in the prescribed order when bending the formwork.

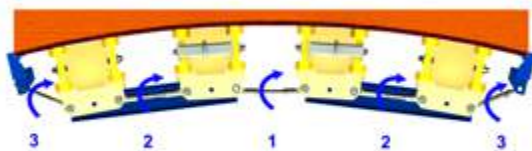

PANELS WIDTH

Elements 2.40 m wide are used for inside formwork, and those 2.50 m wide are designed for outside formwork. This speeds up work by making it easy to see which element belongs where.

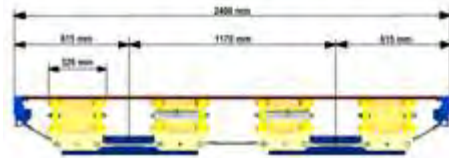

Inner panel

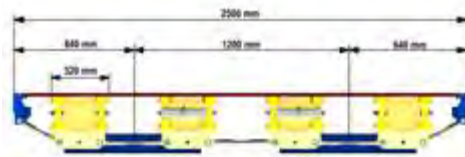









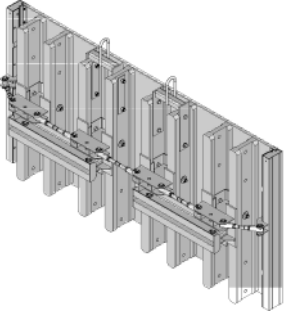

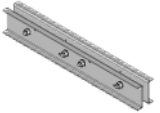

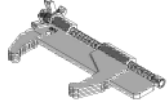

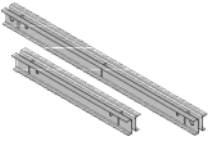



Outer panel





RINGFORM

Item		[kg]	Article n°	Item		[kg]	Article n°
Panel Ringform	2.50x3.00m	543,90	25 100 000	Wall bracket H20		11,46	23 700 100
	2.40x3.00m	532,67	25 102 000				
	2.50x2.40m	483,26	25 104 000				
	2.40x2.40m	472,08	25 106 000				
	2.50x1.20m	261,25	25 108 000				
	2.40x1.20m	257,25	25 110 000				
							
Stacking plate Ringform		9,41	25 504 100	Guide rail clamp		12,40	52 400 100
							
Adjustable clamp Ringform	50-100mm 0-50mm	5,00 4,53	25 500 100 25 502 100	Supporting strut Ringform 340		32,92	25 508 100
							
Clamp device Varimax		3,90	11 902 100	Supporting strut Ringform 540		52,71	25 510 100
							
Guide plate	0.90m 1.50m	11,35 18,85	11 912 000 11 914 000				
							
Stop-end tie Varimax		1,76	11 906 100				
							

Item	[kg]	Article n°	Item	[kg]	Article n°
Adjustable plumbing strut 			Plastic cone 22 mm 	0,005	99 102 400
			Tie rod 15.0 mm 	0.50m 0,80 0.75m 1,20 1.00m 1,60 1.25m 2,00 1.50m 2,40 1.75m 2,80 2.00m 3,20 2.25m 3,60 2.50m 4,00 2.75m 4,40 3.00m 4,80	92 050 300 92 075 300 92 100 300 92 125 300 92 150 300 92 175 300 92 200 300 92 225 300 92 250 300 92 275 300 92 300 300
Strut head Ringform 	1,95	25 506 100			
Spindle element without end-hinge 	36,62	11 934 000			
Extension strut 3.70 m 	78,75	11 936 000			
Extension strut 2.40 m 	54,13	11 938 000			
Spindle element with end-hinge 	43,81	11 940 000			
Rod connector 	15	0,50	95 214 100		
Superplate 	15	1,22	95 200 100		
Plastic tube 22 mm 	2.00m	0,36	99 100 400		



VARIANT

COLUMN FORMWORK

Circular column SK 100

Steel formwork for standard circular cross-sectional columns of any height.

The circular column formwork SK 100 is designed for forming columns with a circular cross-section. To form a curved stop-end or an oval column, the SK 100 system can be combined with Varimax and circular formwork Ringform. This system consists of two semicircular formwork parts of standard diameters ranging from 30 cm up to 130 in a 10 cm grid. The semicircular elements are fixed to each other by means of integrated connectors (no additional fixation elements are required). 3 heights of elements are available they are 50 cm, 100 cm and 200 cm that can be combined by means of vertical stacking to allow assembling construction of any required height.



Heavy-duty formwork:

Permitted pressure of fresh concrete:

- With diameter of up to \varnothing 600 mm - 150 kN/m²;
- With diameter of up to \varnothing 800 mm - 100 kN/m²;
- With diameter of up to \varnothing 1300 mm - 80 kN/m².

Easy to use:

- Availability of only 3 standard element heights and 11 standard diameters in a 10 cm grid provides for easier planning and forming;
- Any custom size with a diameter of up to 200 cm can be produced on request;
- All the connectors are integrated and accessories are easily fixed in the slots and quickly tighten, thus maximizing and making forming time efficient.

Cost-effective:

- Quick concreting operations;
- Installation of pre-assembled units reduces crane use to minimum;
- Only 2 pre-assembled units are used for column forming thus optimizing time needed for forming and stripping;
- High number of use cycles results in lower follow-up expenses;
- Reduction of expenses due to possibility of quick cleaning;
- Powder-coated steel formwork for long service life;
- High quality of concrete finish minimizes finishing work (architectural concrete surface).

Safe use:

- Such accessories as wall brackets, supporting struts, etc. make the system handling safer and easier.



SK 100 elements

ELEMENTS HEIGHTS

There are 3 standard heights of the semicircular formwork element namely 50 cm, 100 cm and 200 cm that can be easily assembled by means of vertical staking to a formwork element of any height required.

ELEMENT DIAMETERS

There are 11 standard diameters of the semicircular formwork elements ranging from 30 cm up to 130 cm in a 10 cm grid.

D = 30, 40, 50, 60, 70, 80, 90, 100, 110, 120, 130 cm

Any custom size of up to 200 cm in diameter can be produced on request.

ELEMENTS FEATURES

The following options are integrated in the SK 100 elements:

- Connectors for linking of two semicircular elements;
- Connectors for vertical stacking;
- Points for crane hooks.

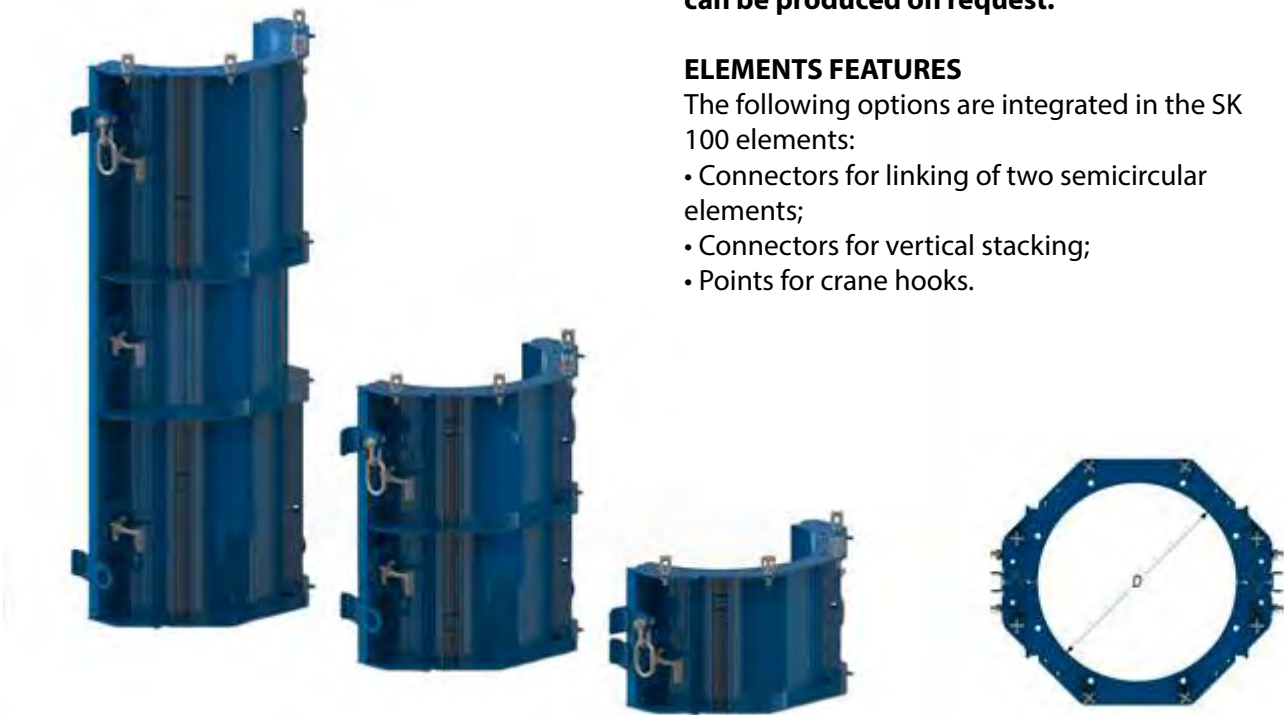

SK 100 elements connection

JOINING OF TWO SEMICIRCULAR ELEMENTS TOGETHER

The integral centering mechanism makes the process of two part positioning easier.



CONNECTION OF THE ELEMENTS FOR STACKING

Join SK 100 elements with the help of integrated connecting SK bolts. To achieve an exact inter-element joint, it is recommended to tighten connection bolts in the following order.

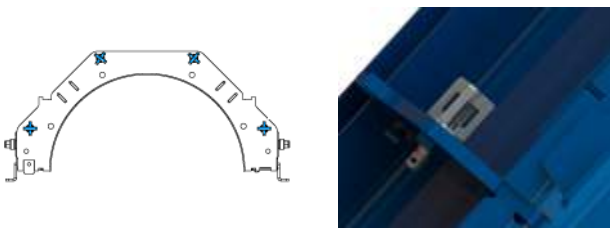

REINFORCEMENT WITH STEEL WALINGS

This measure is recommended for use:

- on high multi-element SK column formworks (starting from 4.00) in order to reinforce the formwork in vertical position;
- on multi-element SK column formworks assembled from a large number of small elements.





The steel walings should be long enough to overlap the reinforcement ribs immediately above and below the joining point.

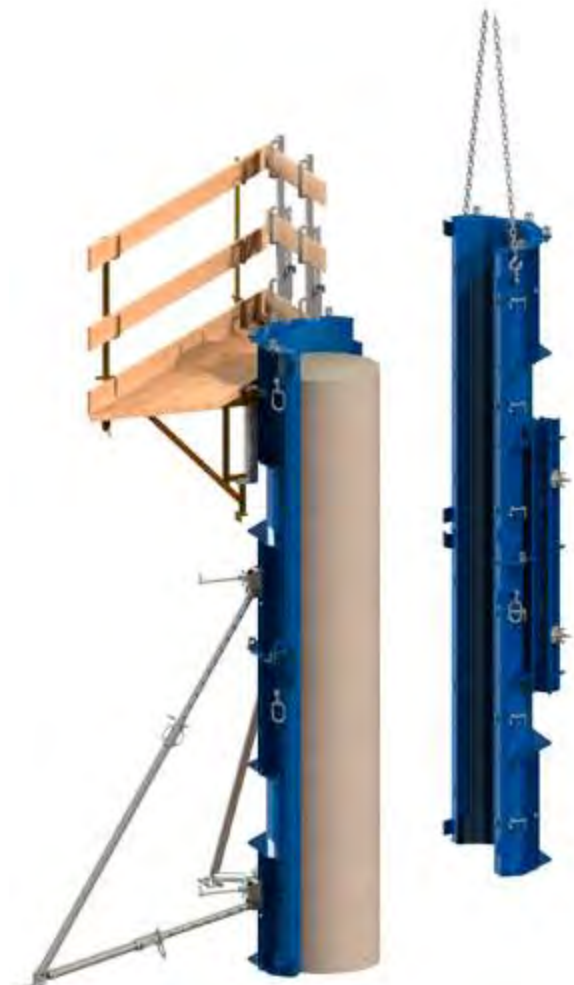
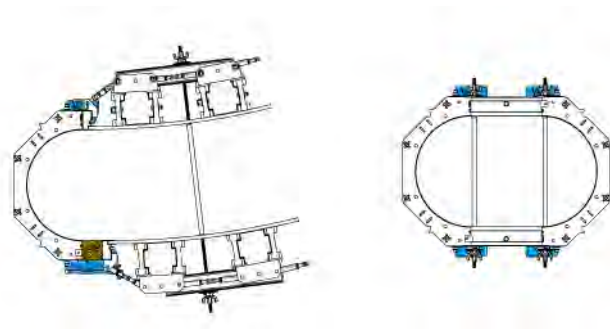



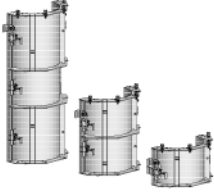
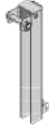
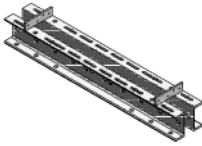

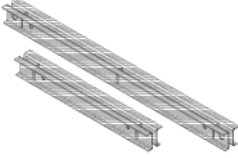

ADDITIONAL APPLICATION

SK 100 elements can be connected directly to Varimax panels to form 'oval' columns or curved stop-end or to the elements of circular Ringform formwork.



SK 100

Item	[kg]	Article n°	Item	[kg]	Article n°
Column element SK 100  Custom size on request	D 1.30x2.00m	336,00	14 100 000	Wall bracket adapter  6,70 ISO 3834	14 166 100
	D 1.30x1.00m	197,40	14 102 000		
	D 1.30x0.50m	114,45	14 104 000		
	D 1.20x2.00m	318,15	14 106 000		
	D 1.20x1.00m	211,05	14 108 000		
	D 1.20x0.50m	107,10	14 110 000		
	D 1.10x2.00m	302,40	14 112 000		
	D 1.10x1.00m	190,05	14 114 000		
	D 1.10x0.50m	100,80	14 116 000		
	D 1.00x2.00m	246,75	14 118 000		
	D 1.00x1.00m	157,50	14 120 000		
	D 1.00x0.50m	88,20	14 122 000		
	D 0.90x2.00m	226,80	14 124 000		
	D 0.90x1.00m	138,60	14 126 000		
	D 0.90x0.50m	80,85	14 128 000		
	D 0.80x2.00m	199,50	14 130 000		
	D 0.80x1.00m	116,03	14 132 000		
	D 0.80x0.50m	68,25	14 134 000		
	D 0.70x2.00m	186,90	14 136 000		
	D 0.70x1.00m	102,90	14 138 000		
	D 0.70x0.50m	59,85	14 140 000		
	D 0.60x2.00m	164,85	14 142 000		
	D 0.60x1.00m	101,33	14 144 000		
	D 0.60x0.50m	54,08	14 146 000		
	D 0.50x2.00m	154,35	14 148 000		
	D 0.50x1.00m	94,50	14 150 000		
	D 0.50x0.50m	54,60	14 152 000		
	D 0.40x2.00m	139,65	14 154 000		
	D 0.40x1.00m	85,05	14 156 000		
	D 0.40x0.50m	48,30	14 158 000		
D 0.30x2.00m	117,60	14 160 000			
D 0.30x1.00m	69,30	14 162 000			
D 0.30x0.50m	39,90	14 164 000			
	ISO 3834				
Waling 12 	1.75m	37,07	21 175 000	Supporting strut 340  37,38 ISO 3834	11 928 100
	2.00m	42,32	21 200 000		
	2.25m	47,46	21 225 000		
	2.50m	52,71	21 250 000		
	2.75m	58,20	21 275 000		
	3.00m	63,53	21 300 000		
	ISO 3834				
Guide plate 	1.50m	18,85	11 914 000	Supporting strut 540  56,91 ISO 3834	11 930 100
	ISO 3834				
Connection screw 	10-16	0,63	11 908 100		
	10-25	0,79	11 910 100		

Item	[kg]	Article n°	Item	[kg]	Article n°
Adjustable plumbing strut 					
Spindle head 	3,48	11 932 100			
Spindle element without end-hinge 	36,62	11 934 000			
Extension strut 3.70 m 	78,75	11 936 000			
Extension strut 2.40 m 	54,13	11 938 000			
Spindle element with end-hinge 	43,81	11 940 000			
Superplate 	15	1,22	95 200 100		

Column formwork VARIMAX

Framed heavy-duty formwork for forming of rectangular and square columns.

This system is widely used for projects where large number of square and rectangular columns with variable cross-sections should be formed with low cash and time expenses. Versatile panels of the VARIMAX system are used for column forming. With the versatile panels 90 cm wide a column cross-section with a size of up to 75x75 cm in a 5 cm grid can be formed and when using a 135 cm panel a column cross-section with a size of up to 120x120 cm in a 5 cm grid can be formed. Height extension can be achieved by means of vertical stacking.

Heavy-duty formwork:

- 80 kN/m² pressure of fresh concrete;
- High quality film faced plywood with a thickness of 21 mm. Film weight is 240 g/m².

Easy to use:

- A range of only 2 standard panel widths provides for easier planning and forming;
- All the connectors and accessories are easily fixed in the slots and quickly tighten, thus maximizing and making forming time efficient;
- Any column cross-section with a size of up to 120x120 cm in a 5 cm grid can be easily assembled.

Cost-effective:

- The formwork is used for maximum when installed with the use of versatile panels for columns, corners, stop-ends and wall junctions;
- Installation of pre-assembled units reduces crane use to minimum;
- Only 2 pre-assembled units are used for column forming thus optimizing time needed for forming and stripping;
- High number of use cycles results in lower follow-up expenses;
- Reduction of expenses due to possibility of restoration and cleaning;
- Galvanized or powder-coated steel frames for long service life;
- High quality of concrete surface reduces finishing work to minimum.

Safe use

- Such accessories as wall brackets, lifting hooks, supporting struts, etc. make the system handling safer and easier.





VARIMAX versatile panels

VERSATILE PANELS

The special hole pattern makes these panels particularly suitable for efficient forming of:

- Columns;
- Corners;
- Wall junctions;
- Stop-ends.

For any type and size of the panel two options of covering are available.



Galvanized

Powder-coated

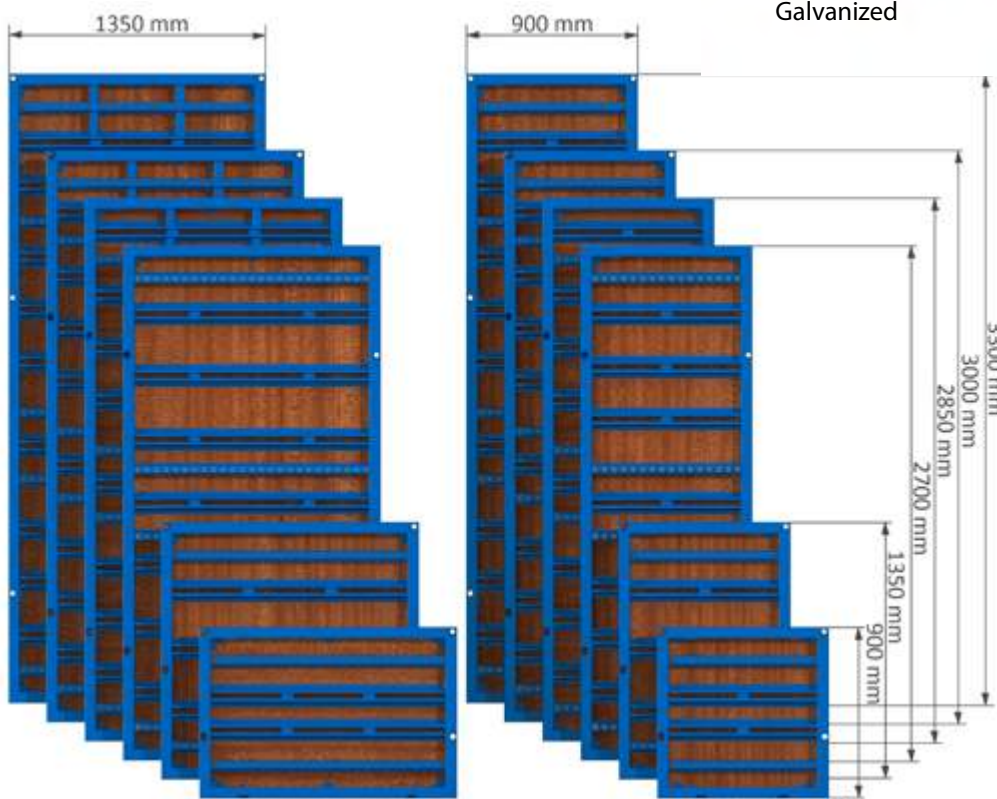

VERSATILE PANEL CONNECTION

To join the panels, connectors of one type are used installed with the use of variant connection screw 10-16 and superplate 15th us simplifying and speeding up pre-assembly, forming and stripping processes.



Superplate 15



Connection screw 10-16

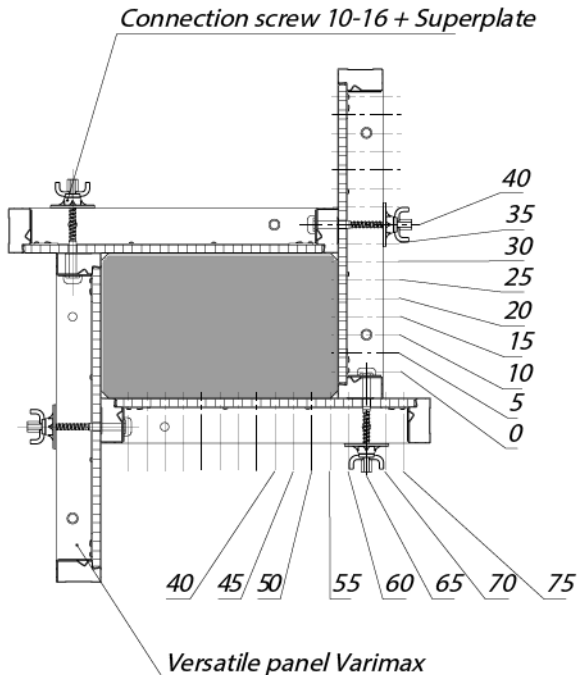

Column formwork VARIMID

Framed lightweight formwork for forming of rectangular and square columns.

The lightweight framed formwork Varimid by Variant delivers perfect forming performance when crane use is limited and they can be manually assembled. Column formwork Varimid is considered to be the best solution in case there is a need to form a large number of square and rectangular columns with variable cross-sections with low cash and time expenses and limited use of lifting equipment. With the versatile panels 75 cm wide a column cross-section with a size of up to 60x60 cm in a 5 cm grid can be formed and when using a 90 cm panel a column cross-section with a size of up to 75x75 cm in a 5 cm grid can be formed. Height extension can be achieved by means of vertical stacking. Maximum height of a column set is 6 m with one staking joint.

High load-bearing capacity:

- 60 kN/m² pressure of fresh concrete;
- Possibility of vertical stacking to the height of up to 6.00 m with the use of one joint;
- High quality film faced plywood with a thickness of 15 mm. Film weight is 240 g/m².

Cost-effective:

- Manhandled formwork panels minimize crane use;
- High number of use cycles results in lower follow-up expenses;
- Reduction of expenses due to possibility of restoration and cleaning;
- Galvanized or powder-coated steel frames for long service life;
- High quality of concrete surface minimize finishing work;
- Reduction of cost by means of panel re-use;
- The formwork is used for maximum when installed with the use of versatile panels for forming of stop-ends, corners, wall junctions, etc.

Easy handling and planning:

- All the connectors and accessories are easily fixed in the slots and quickly tighten, thus maximizing and making forming time efficient.

Safe use:

- Such accessories as wall brackets, lifting hooks, supporting struts, etc. make the system handling safer and easier.





VARIMID versatile panels

VERSATILE PANELS

Special hole pattern makes these panels particularly suitable for efficient forming of:

- Corners;
- Wall junctions;
- Stop-ends;
- Columns.

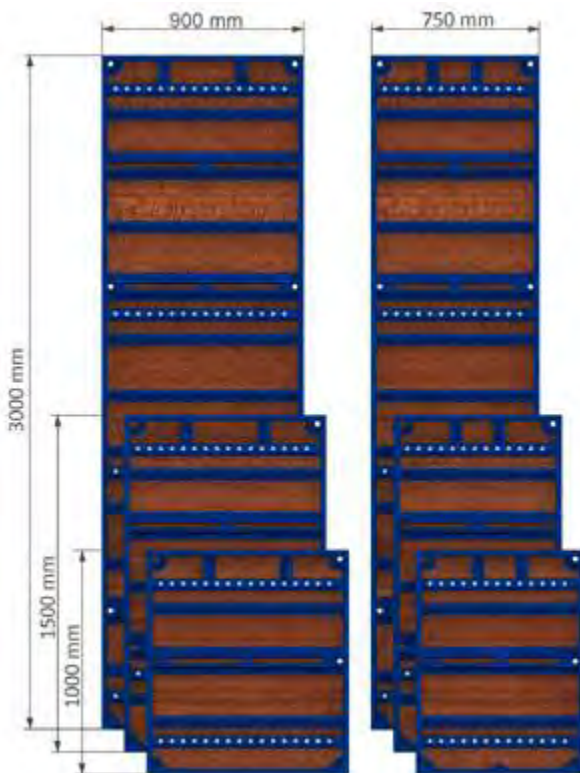

For any panel type and size there are two options of covering available.



Galvanized



Powder-coated



VERSATILE PANEL CONNECTION

To join the panels, connectors of one type are used installed with the use of variant connection screw 10-16 and superplate 15, thus simplifying and speeding up pre-assembly, forming and stripping processes.



Connection screw 10-16



Superplate 15

Possible cross-sections in a 5 cm increment grid

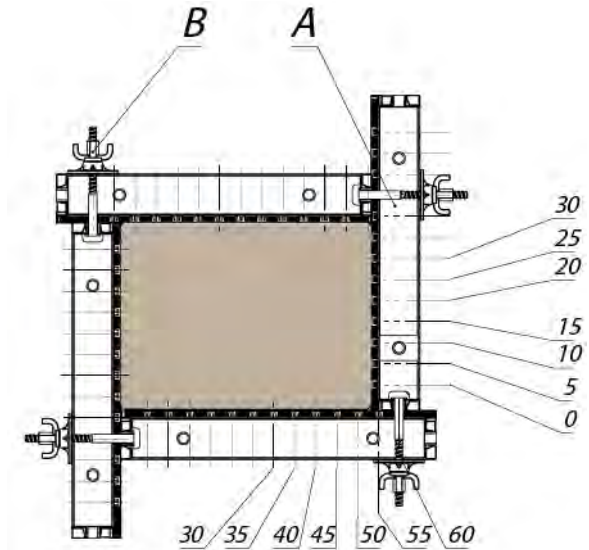

With the use of a 75 cm versatile panel, a cross-section of up to 60x60 cm in a 5 cm grid can be formed.

With the use of a 90 cm versatile panel, a cross-section of up to 75x75 cm in a 5 cm grid can be formed.



Column formwork HANDI

Framed super-lightweight formwork for column forming.

The Handi is a super-lightweight framed formwork that was specially designed for quick and cost-effective construction. Owing to its super-lightweight panels, the system can be manually handled and assembled with ease. Thus, for column forming the Handi system can be ideally used in projects where a large number of square and rectangular columns with variable cross-sections need to be formed with the limited crane use and when it is complicated to use heavier framed formwork systems (such as Varimax system). Versatile panels of the Handi system are used to form a column section. With a versatile panel 60 cm wide, column cross-section of up to 50x50 cm can be formed in a 5 cm grid. With a versatile panel 90 cm wide, column cross-section of up to 80x80 cm can be formed in a 5 cm grid (it is recommended not to increase cross-section sizes of 60x60 cm due to high pressure of fresh concrete).

Load-bearing capacity:

- 35 kN/m² pressure of fresh concrete;
- High quality film faced plywood with a thickness of 15 mm. Film weight is 240 g/m².

Cost-effective:

- Universal application of the Handi system will give you an opportunity to use one system for different tasks;
- Reduction of expenses due to minimizing of crane use;
- High number of use cycles results in lower follow-up expenses;
- Reduction of expenses due to possibility of restoration and cleaning;
- Galvanized or powder-coated steel frames for long service life;
- High quality of concrete surface reduces finishing work to minimum;
- Reduction of expenses by means of panel re-use;
- The formwork is used for maximum when installed with the use of versatile panels for forming of stop-ends, corners, wall junctions, etc.

Easy to use

- All the connectors and accessories are easily fixed in the slots and quickly tighten, thus maximizing and making forming time efficient;
- Ergonomic of the system ensures fast and save assembly.

Safe use

- Such accessories as wall brackets, lifting hooks, supporting struts, etc. make the system handling safer and easier.



HANDI versatile panels

VERSATILE PANELS



Special hole pattern makes these panels particularly suitable for efficient forming of:

- Corners;
- Wall junctions;
- Columns.

For any panel type and size there are two options of covering available.



Galvanized



Powder-coated

Versatile panels connection

To join the panels, connectors of one type are used installed with the use of variant connection screw 10-16 and star-shaped nut with a washer, thus simplifying and speeding up pre-assembly, forming and stripping processes.



Connection screw 5-10



Star-shaped nut



Use of versatile panels 90 cm

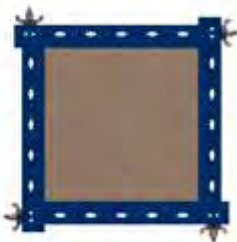

Use of versatile panels 60 cm

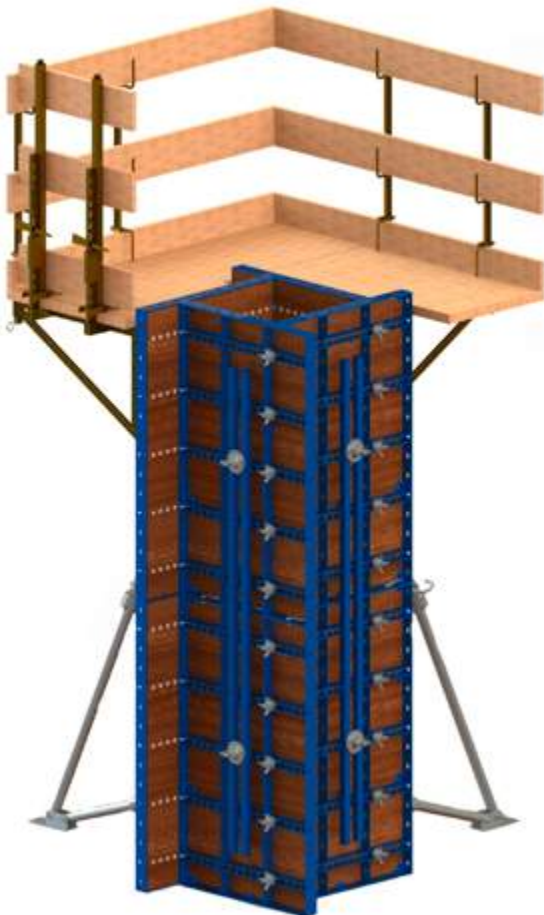

Column formwork VERTEX 60

Formwork system for forming columns of any size and shape.

Owing to flexibility of this system, column formwork VERTEX 60 allows forming columns and pillars of different types, shapes and sizes of cross-section. Maximum height of the formwork set is 12 m and it can be achieved by means of vertical stacking. Depending on the distance between walings and H20 beams, VERTEX 60 can be easily adapted to any requirements and loads. Maximum permitted pressure of fresh concrete is 80 kN/m². In order to maximize utility, column formwork sets of VERTEX 60 are designed and pre-assembled for a particular project and purpose (including shape, size and height of column cross-section). There is no need to use tie-rods in column cross-section of up to 120x120. Erection of the column formwork Vertex 60 is carried out quickly, reliably and cost-effectively.

Adaptable load-bearing capacity:

- Due to its adaptability Vertex 60 can be assembled and customized to withstand almost any pressure of fresh concrete up to 80 kN/m².

Cost-effective:

- Ideal for cost-effective forming of a wide column range. For fast operation it is recommended to use one set of pre-assembled formwork for a particular cross-section size;
- Pre-assembled sets can be used to maximize utility and optimize forming time;
- High number of use cycles results in lower follow-up expenses;
- High quality of concrete surface reduces finishing work to minimum;
- Project-specific adaptation is possible as it can be faced with any type of form-ply.

Easy handling and planning

- All the connectors and accessories are easily fixed in the slots and quickly tighten, thus maximizing and making forming time efficient;
- Load-bearing capacity of the system can be adjusted by means of H20 beams and steel walings;
- Any requirements for architectural concrete design and shape of the column cross-section can be met due to the system adaptability.

Safe use

- Such accessories as wall brackets, lifting hooks, supporting struts, etc. make the system handling safer and easier.





Design and pre-assembly of column formwork VERTEX 60

Depending on waling arrangement and distance between H20 beams, a maximum fresh concrete pressure of 80 kN/m^2 can be reached.

All column cross-sections of up to 120×120 can be assembled with the help of standard equipment without necessity to use tie-rods. Circular columns and columns with cross-section of special shape can be also encased.

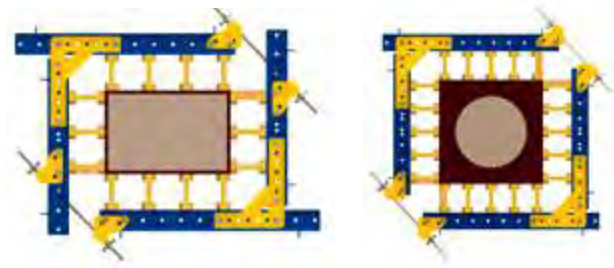

Rectangular column formwork

Circular column formwork

Elements of connection for column formwork VERTEX 60

Column corner plate rigidly and precisely connects walings in a pre-assembled part (gang-form) of the formwork installed across the corner.

In order to connect two parts (gang-forms) of the column together, **corner tie brackets** are used and they are tightened and fixed by means of tie-rods and wing nuts. The corner tie bracket provides for diagonal tension-brace of walings and makes forming and striking easier and faster.



Corner tie bracket



Column corner plate



VERTEX 60 column formwork





VARIANT

**SINGLE-SIDED
FORMWORK**

Modular supporting frames

Tried and checked system for single-sided walls forming with a height of up to 8.00 m.

The system of modular supporting frames by Variant is used for single-sided walls forming such as retaining walls, dam walls, etc. Shear forces acting on the formwork shutters due to fresh concrete pressure are held and redistributed over the base by means of modular supporting frames and diagonal anchors. Single-sided supporting system provides for forming of the walls with the required pouring-height of up to 8.00 m.

Load-bearing capacity :

- Owing to its load-bearing flexibility, the single-sided modular supporting system can be assembled and customized for different pressure of fresh concrete up to 50 kN/m².

System adaptability:

- Flexible height adjustment;
- It easily combines with Variant wall systems such as framed formwork Varimax and large-area formwork Vertex 60;
- Rapid adaptation to any unevenness of the installation site;
- Special application is possible (e.g. when positioned horizontally and anchored to the structure used as heavy-duty working platforms).

Cost-effective:

- Can be repositioned with the help of wheel units in order to save crane time;
- Large areas of single-sided wall can be easily cast;
- High number of use cycles results in lower future expenses;
- Reduction of expenses by means of system adaptability;
- Galvanized steel frames for long service life.

Easy handling and planning:

- All the connectors and accessories are easily fixed in the slots and quickly tighten, thus maximizing and making forming time efficient;
- Any requirements for architectural concrete design can be met.

Safe use:

- Such accessories as wall brackets make the system handling safer and easier.

Single-sided modular supporting system applications:

- Retaining walls;
- Dam walls;
- Stop-ends of walls and slabs with large thickness;
- Walls of great thickness, in this case single-sided system should be installed on both sides;
- Walls with no place for installation of opposite formwork shutter (double-sided system).

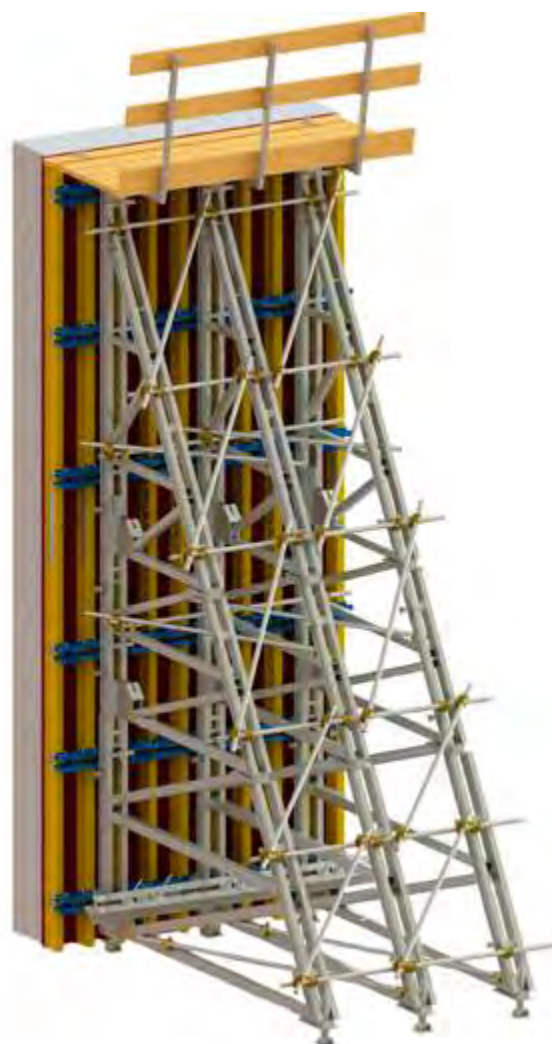



Modular supporting frames — supporting units assembly

TYPES AND SIZES

The supporting modular frame units are formed by means of combining supporting or attachable frames in one block with bracing. The modular units must be correctly braced with scaffold tubes to attain stated capacity.

There are 3 types of modular units that can be formed by combing the following frames:

- Supporting frame of 4.50 m;
- Attachable frame of 1.50 m;
- Attachable frame of 2.00 m.

Supporting modular units are assembled in the same way to be used either with a timber-beam or a framed formwork.



Modular supporting unit formed by combing supporting frames of 4.50 m



Modular supporting unit formed by combing attachable frames of 1.50 m



Modular supporting unit formed by combing attachable frames of 2.00 m

Modular supporting frames — combining with wall formwork

Single-sided modular supporting system easily combines with such Variant wall formwork systems as framed formwork Varimax and large-area formwork Vertex 60.

Supporting modular units are assembled in the same way to be used either with a timber-beam or a framed formwork.

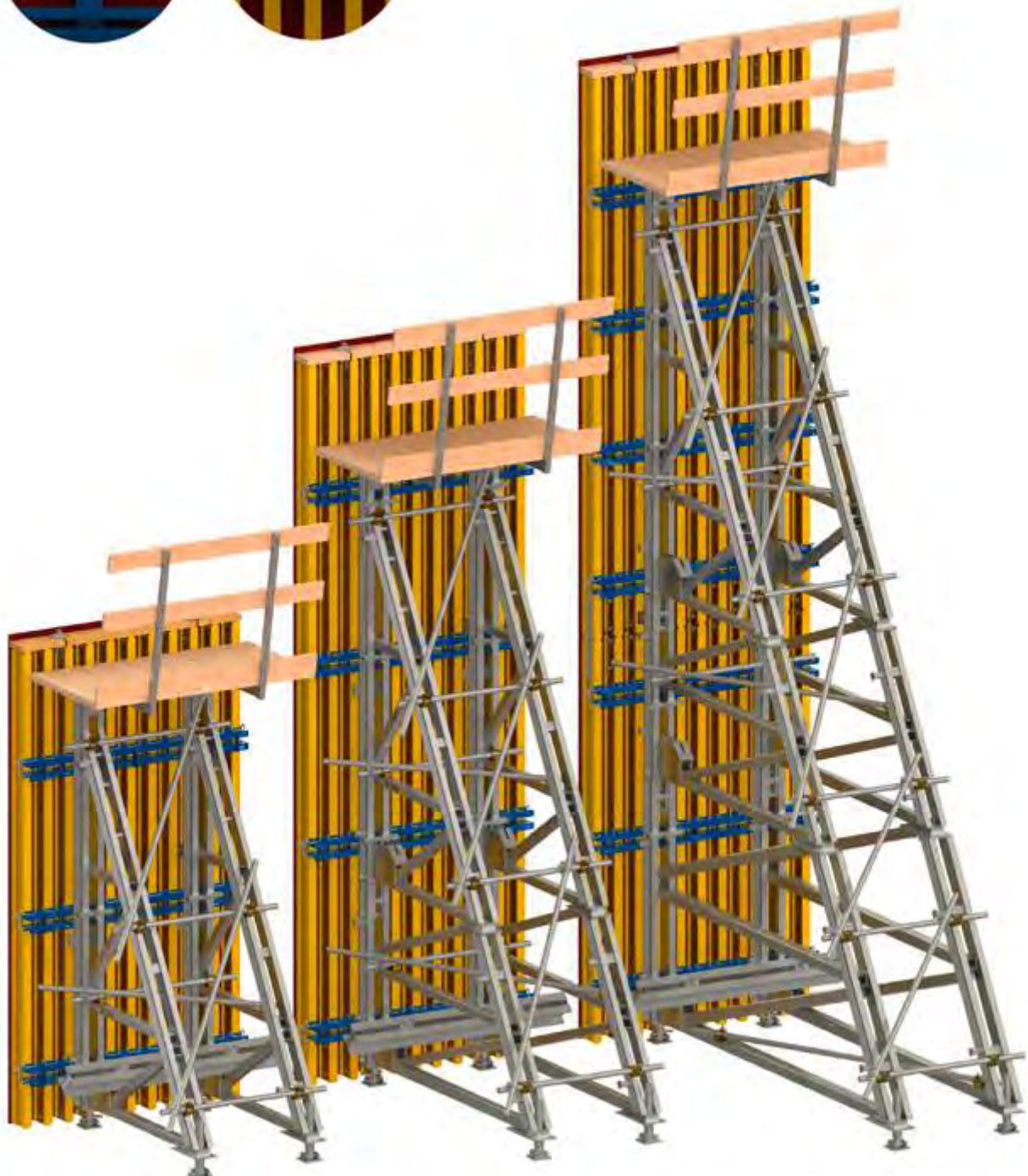
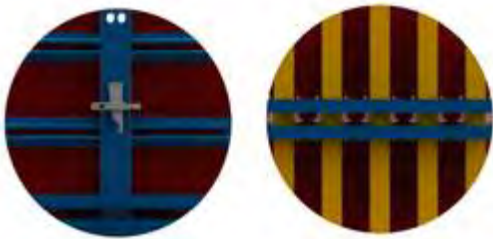

Modular supporting frames — combining with wall formwork

FIXATION OF FRAMED FORMWORK VARIMAX

In order to fix Varimax panels to the modular supporting frames, walings 10 or 12 are used and they are fixed to the framed formwork by means of a connection screw 10-16 and Superplate 15. Then the panel is fixed to the modular supporting frames with a waling-to-bracket holder.

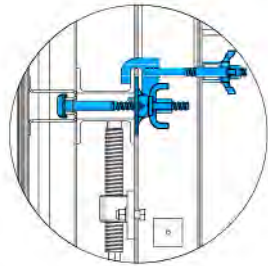

FIXATION OF TIMBER-BEAM FORMWORK VERTEX 60

Vertex 60 formwork elements are clamped directly onto the modular supporting frame with a waling-to-bracket holder. The modular supporting frames are designed in such a way for waling of formwork shutter to be fixed in any point of the frame.

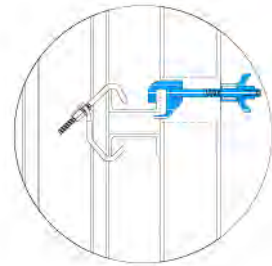





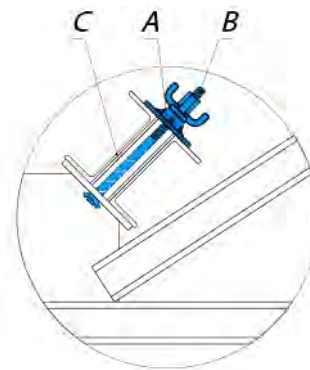
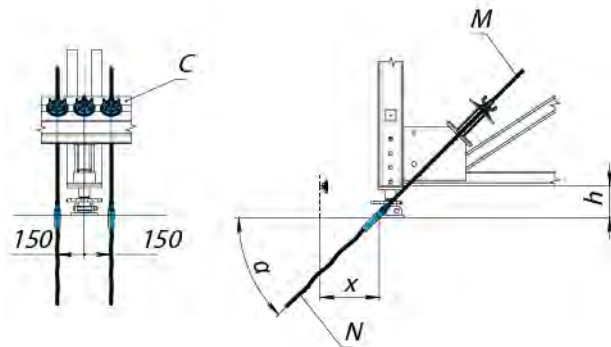

























Modular supporting frames— anchoring

Horizontal forces acting on the single-sided formwork due to fresh concrete pressure are held by the modular supporting units and redistributed onto the ground by diagonal anchors. The diagonal anchors are fixed to the anchor waling of the modular supporting unit with a superplate.



















Besides a superplate 15 (A), the anchor waling positioner (B) also secures it (C) in such a way for anchor waling not to tilt or slip out of the position.





Modular supporting frames

Item	[kg]	Article n°	Item	[kg]	Article n°
Supporting frame 4.50 m 	350,87 	31 001 200	Corner plate MSF 	47,25 	32 100 100
			Front spindle MSF 	19,43 	32 106 100
Attachable frame 1.50 m 	263,67 	31 002 200	Rear spindle MSF 	19,18 	32 104 100
			Adjusting spindle 	6,62 	32 102 100
Attachable frame 2.00 m 	497,04 	31 003 200	Connecting pin 	0,39	23 400 100
			Spring cotter 	0,05	23 402 100
Waling 12 	1.00m 21,00 2.00m 42,32 3.00m 63,53 	21 100 000 21 200 000 21 300 000	Connection screw	10-16 0,63	11 908 100
					
Anchor waling 18 	0.70m 26,45 1.95m 72,40 2.95m 108,93 	33 070 200 33 195 200 33 295 200	Wailing-to bracket holder 	2,61 	75 200 100
					
Special anchor waling 	0,55m 47,39 	33 055 200	Screw-on access bracket 	17,32 	75 116 100
Anchor walina positioner 	0,63 	32 108 100			

Modular supporting frames

		[kg]	Article n°	Item	[kg]	Article n°		
Swivel plate 		4,10	75 118 100	She-bolt 	15.0mm 0.65m	1,83	95 304 100	
					15.0mm 1.20m	2,72	95 306 100	
					20.0mm 1.25m	5,94	95 308 100	
Attachable roller A for supporting frame 4.50 m 		9,78	34 100 000	Tie rod 	15.0mm 1.50m	2,40	92 150 300	
					20.0mm 1.50m	3,60	93 150 300	
					26.5mm 1.50m	6,83	95 310 300	
Attachable roller B for supporting frame 4.50 m 		41,06	34 102 000	Rod connector 	15	0,50	95 214 100	
Adjustable jack 		30,45	34 104 000	Clearance cone 	15	0,38	95 300 100	
					20	0,38	95 302 100	
				Anchoring cone 	20	1,05	95 312 100	
Framed tube 48 mm 	1.00m	4,60	94 100 200	Superplate 	15	1,22	95 200 100	
	1.50m	6,91	94 150 200		20	2,10	95 202 100	
	2.00m	9,21	94 200 200	Hexagon nut 	15	0,37	95 208 100	
	2.50m	11,51	94 250 200		26.5	0,80	95 218 100	
	3.00m	13,81	94 300 200					
Swivel coupler 	48x48mm	1,22	95 106 100	Rod connector 	26.5	1,51	95 216 100	
Screw-on coupler 48 mm 		30	1,21	95 100 100	Anchor plate 	26.5	3,47	95 220 100
		70	1,26	95 102 100				
		100	1,33	95 104 100				

Modular supporting frames

Item		[kg]	Article n°	Item	[kg]	Article n°
Pigtail anchor 	15	0,92	99 208 300			
	20	1,90	99 210 300			
	26.5	3,60	99 212 300			
Stop anchor 	15.0mm 0.16m	0,43	99 200 100			
	15.0mm 0.40m	1,07	99 202 100			
	20.0mm 0.22m	0,64	99 204 100			
	20.0mm 0.45m	1,30	99 206 100			
Sealing sleeve 	15	0,008	99 104 400			
	20	0,03	99 106 400			
Anchor holder 	15	0,34	99 214 300			
	20	0,42	99 216 300			
						

Adjustable supporting frames

Tried and tested system for single-sided walls forming with a height of up to 4.00 m.

The system of adjustable supporting frames by Variant is used for forming single-sided walls including retaining walls, dam walls, etc. Shear forces acting on the formwork shutters due to fresh concrete pressure are held and redistributed over the base by means of adjustable supporting frames and diagonal anchors. Single-sided supporting system provides for forming of the walls with the required pouring-height of up to 4.00 m.

Load-bearing capacity:

- Owing to its load-bearing flexibility, the single - sided adjustable supporting system can be assembled and customized for different pressure of fresh concrete up to 50 kN/m².

System adaptability:

- Easily combines with such Variant wall systems as framed formwork Varimax and timber-beam formwork Vertex 60.

Cost-effective:

- Can be manually assembled, disassembled and repositioned;
- Large-areas of single-sided walls can be easily cast;
- High number of use cycles results in lower follow- up expenses;
- Reduction of expenses by means of system adaptability;
- Powder coated steel elements for long service life.

Easy handling and planning:

- All the connectors and accessories are easily fixed in the slots and quickly tighten, thus maximizing and making forming time efficient;
- Any requirements for architectural concrete design can be met.

Safe use:

- Such accessories as bracing platforms make the system handling safer and easier.

Single-sided adjustable supporting system applications:

- Retaining walls;
- Dam walls;
- Stop-ends of walls and slabs with large thickness;
- Walls of great thickness, in this case single-sided system should be installed on both sides;
- Walls with no place for installation of opposite formwork shutter (double-sided system).





Adjustable supporting frames – assembly of supporting units

The adjustable supporting units are formed by means of combining steel section elements, walings 12, spindle struts in one block. The adjustable units should be correctly braced with scaffold tubes to attain the stated capacity.

There are 2 types of modular units that can be formed:

- Adjustable supporting unit for pour height of up to 3.25 m;
- Extended adjustable supporting unit for pour height of up to 4.00 m.

The supporting modular units are assembled in the same way to be used either with a timber-beam or a framed formwork.



Adjustable supporting unit for a pour height of up to 3.25 m



Extended adjustable supporting unit for a pour height of up to 4.05 m



In case of necessity, the adjustable supporting unit can be assembled with the use of 3 parallel frames

Adjustable supporting frames – combining with wall formwork

Single-sided adjustable supporting system easily combines with such Variant wall formwork systems as framed formwork Varimax and timber-beam formwork Vertex 60.

The supporting adjustable units are assembled in the same way to be used either with a timber-beam or a framed formwork.



Adjustable supporting frames – combining with wall formwork

FIXATION OF FRAMED FORMWORK VARIMAX

In order to fix Varimax panels to the modular supporting frames, walings 10 or 12 are used and they are fixed to the framed formwork by means of a connection screw 10-16 and Superplate 15. Then the panel is fixed to the adjustable supporting frames with a waling-to-bracket holder.

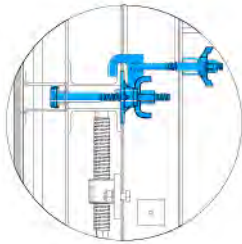

FIXATION OF TIMBER-BEAM FORMWORK VERTEX 60

Vertex 60 formwork elements are clamped directly onto the adjustable supporting frame with a waling-to-bracket holder. The adjustable supporting frames are designed in such a way for waling of formwork shutter to be fixed in any point of the frame.

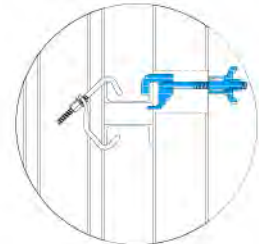

Adjustable supporting frames – anchoring

Forces acting on the single-sided formwork due to fresh concrete pressure are held by the adjustable supporting units and redistributed onto the ground by diagonal anchors. The diagonal anchors are fixed to the anchor waling of the adjustable supporting unit with a superplate.

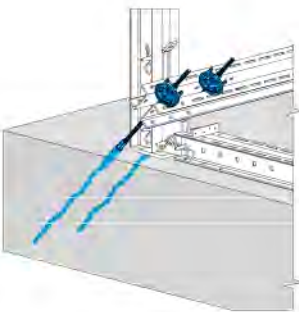

Anchoring with a pigtail anchor

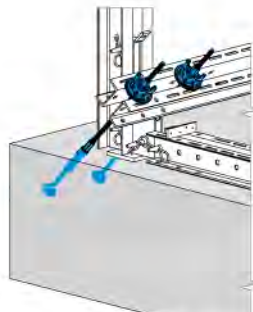

Anchoring with a stop-anchor

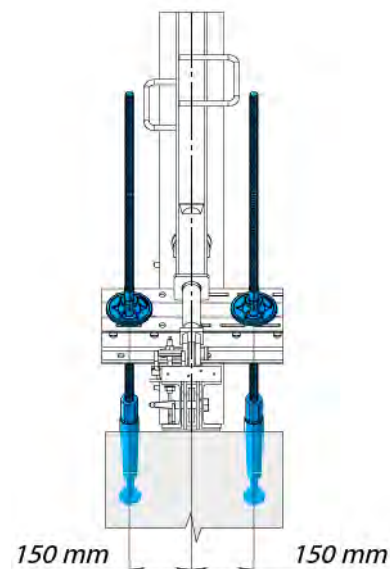



























Distance between anchors for either pigtail anchor or stop-anchor system.





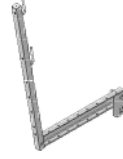







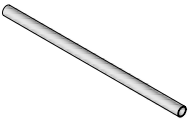

Adjustable supporting frames



Adjustable supporting frames

Item	[kg]	Article n°	Item	[kg]	Article n°
Steel section ASF 	65,84 	35 100 000	Waling 12 	1.00m 21,00 2.00m 42,32 3.00m 63,53 	21 100 000 21 200 000 21 300 000
Anchoring shoe ASF 	12,34 	35 102 100	Anchor waling 14 	1.60m 45,34 2.00m 56,06 2.60m 73,60 	36 160 200 36 200 200 36 260 200
Supporting shoe ASF 	10,21 	35 104 100	Connecting plate Vertex 	6,47 	23 404 000
Pressure shoe ASF 	6,29 	35 106 100	Connecting pin 	0,39	23 400 100
Tension plate ASF 	2,61 	35 108 100	Spring cotter 	0,05	23 402 100
Spindle strut ASF 	3.00m 34,79 	35 200 100	Connecting screw 	10-16cm 0,63	11 908 100
			Waling-to-bracket holder 	2,61 	75 200 10
Spindle strut T7 	3.05-3.55m 36,05 	35 202 100	Screw-on access bracket 	17,32 	75 116 100
			Swivel plate 	4,10	75 118 100

Adjustable supporting frames

Item		[kg]	Article n°	Item		[kg]	Article n°
Supporting strut 340 		37,38	11 928 100	Clearance cone 	15,0	0,38	95 300 100
					20,0	0,38	95 302 100
Framed tube 48 mm 	1.00m	4,60	94 100 200	Anchoring cone 	20,0	1,05	95 312 100
	1.50m	6,91	94 150 200				
	2.00m	9,21	94 200 200				
	2.50m	11,51	94 250 200	Pigtail anchor 	15	0,92	99 208 300
	3.00m	13,81	94 300 200		20	1,90	99 210 300
Swivel coupler 	48x48mm	1,22	95 106 100	Stop anchor 	15.0mm 0.16m	0,43	99 200 100
					15.0mm 0.40m	1,07	99 202 100
					20.0mm 0.22m	0,64	99 204 100
				20.0mm 0.45m	1,30	99 206 100	
Screw-on coupler 48 mm 	30	1,21	95 100 100	Sealing sleeve 	15	0,008	99 104 400
	70	1,26	95 102 100		20	0,03	99 106 400
	100	1,33	95 104 100				
Superplate 	15	1,22	95 200 100	Anchor holder 	15	0,34	99 214 300
	20	2,10	95 202 100		20	0,42	99 216 300
							
She-bolt 	15.0mm 0.65m	1,83	95 304 100				
	15.0mm 1.20m	2,72	95 306 100				
	20.0mm 1.25m	5,94	95 308 100				
Tie rod 	15.0mm 1.50m	2,40	92 150 300				
	20.0mm 1.50m	3,60	93 150 300				
Rod connector 	15,0	0,50	95 214 100				



VARIANT

SLAB FORMWORK SYSTEMS

Slab formwork VARIFLEX

Flexible system for fast and cost-effective forming of concrete slabs.

Variflex by Variant is a conventional prop formwork system for forming and shoring of flat slabs. Consisting only of 5 main components, this system is quick and easy to assembly, thus optimizing operational time and labor costs. Variflex can adapt to any slab application due to beam overlap and the prop ability to be placed at any point of the main beam. The system can be applied to any load simply by changing only 3 variables (distance between main rows, distance between props in the main row and distance between secondary beams).

Load-bearing capacity :

- Due to its load-bearing flexibility Variflex can be adapted to withstand any loads caused by fresh concrete when using slabs of different thickness. It can be optimally and cost-effectively used within a range of slab thicknesses of up to 500 mm;
- Maximum formwork height is 6.0 m.

Cost-effective:

- The use of fewer elements speeds up assembly process;
- Manual assembly, stripping and disassembly;
- High number of use cycles results in lower follow-up expenses;
- Reduction of expenses due to system adaptability;
- Galvanized or powder coated elements for long service life.

System adaptability:

- It easily adapts to different and varying layouts, especially in case of irregular geometry, specific force acting, and different slab thicknesses.

Easy handling and planning:

- All the connectors and accessories are easily fixed in the slots and quickly tighten, thus maximizing and making forming time efficient;
- All the architectural requirements to concrete flat slab design can be met.

Safe use:

- Such accessories as handrail make the system handling safer and easier;
- Safe processing during assembly.

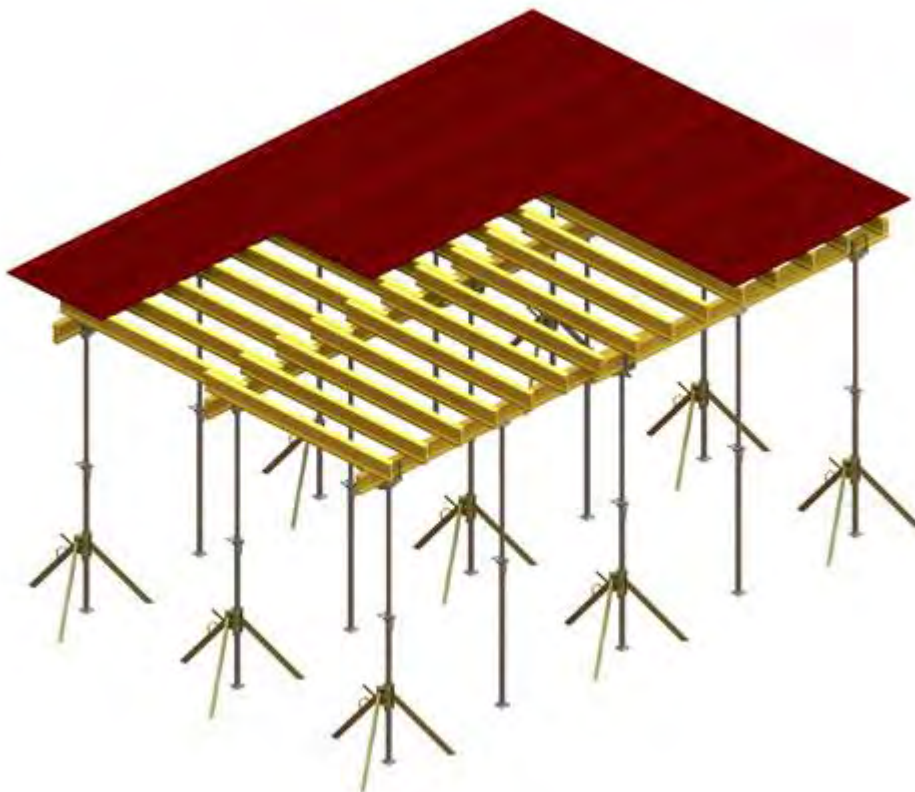



VARIFLEX— system overview

The key benefit of Variflex is that it is easy adaptable to different layouts. Owing to relatively low material costs, Variflex allows for cost-effective solutions even in case of several concrete pours.

- The use of fewer elements speeds up assembly process;
- Manual assembly and stripping without crane use;
- Adaptation to slab thicknesses and layouts of all types;
- Wide range of facings;
- Wide range of Variant props.



(A) Facing

Any kind of facing can be used ranging from conventional plywood and plastic panels to permanent formwork panels.

(B) H20 beams

Redistribution of loads caused by fresh concrete on the props.

(C) Lowering head (Crown head)

It is used in connection with supporting props as a main support of primary beams. Lowering head integrates quick-lowering function for fast stripping.

(D) Support head

It is used to connect intermediate props to the primary beams.









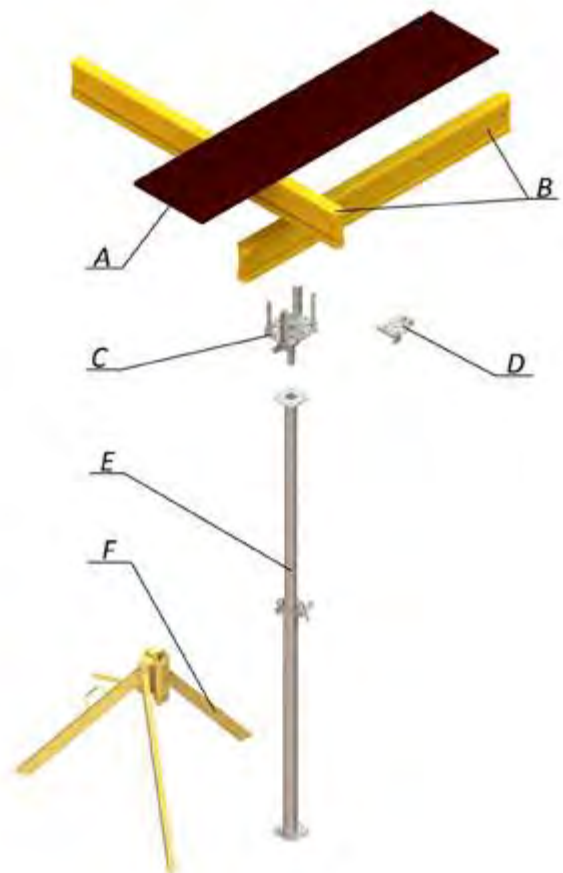



(E) Supporting prop

There is a wide range of Variant supporting props that can be used with the system. The choice is to be made depending on loads, formwork height and working conditions.























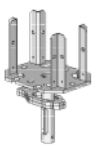



(F) Removable folding tripod

It is used for aligning and holding props upright during formwork assembly and stripping.



Item		[kg]	Article n°	Item		[kg]	Article n°
Heav duty prop RBGU 	1.50m	13,45	51 115 000	Light duty prop RBGE 	2.50m	9,67	51 325 000
	2.50m	17,29	51 125 000		3.00m	10,97	51 330 000
	3.00m	20,49	51 130 000		3.50m	12,15	51 335 000
	3.50m	22,66	51 135 000		4.00m	13,45	51 340 000
	4.00m	24,84	51 140 000		4.50m	14,70	51 345 000
	4.50m	27,02	51 145 000				
	5.00m	29,20	51 150 000				
	5.50m	31,36	51 155 000				
							
Options available: xx xxx 000 - Powder coated xx xxx 200 - Hot dip galvanized Custom size on request				Options available: xx xxx 000 - Powder coated xx xxx 100 - Galvanized xx xxx 200 - Hot dip galvanized Custom size on request			
Medium duty prop RBGN 	2.50m	11,15	51 225 000	Extra light duty prop RBR 57 	3.00m	8,51	51 730 000
	3.00m	12,58	51 230 000		3.50m	9,56	51 735 000
	3.50m	14,16	51 235 000				
	4.00m	16,02	51 240 000				
	4.50m	17,45	51 245 000				
	5.00m	18,88	51 250 000				
			EN 1065/B				
Options available: xx xxx 000 - Powder coated xx xxx 100 - Galvanized xx xxx 200 - Hot dip galvanized Custom size on request				Options available: xx xxx 000 - Powder coated xx xxx 100 - Galvanized xx xxx 200 - Hot dip galvanized Custom size on request			
Medium duty prop RBG 	2.50m	10,87	51 425 000	Extra light duty prop RBR 48 	3.00m	7,44	51 630 000
	3.00m	12,30	51 430 000		3.50m	8,24	51 635 000
	3.50m	13,55	51 435 000				
	4.00m	14,94	51 440 000				
	4.50m	16,38	51 445 000				
	5.00m	17,80	51 450 000				
							
Options available: xx xxx 000 - Powder coated xx xxx 100 - Galvanized xx xxx 200 - Hot dip galvanized Custom size on request				Options available: xx xxx 000 - Powder coated xx xxx 100 - Galvanized xx xxx 200 - Hot dip galvanized Custom size on request			

VARIFLEX

Item	[kg]	Article n°	Item	[kg]	Article n°
Tripod W 	15,75	52 100 100	Spring locked connection pin 16 mm 	0,23	52 310 100
					
			Beam forming support 	7,77	52 302 000
					
Tripod L 	7,80	52 102 100	Extension for beam forming support 	3,83	52 304 100
					
Tripod L light 	6,42	52 104 100			
					
			Bracing clamp 	1,45	52 300 100
Lowering head 	6,33	52 200 100	Bracing frame Variflex 	1.50m 17,04 1.80m 18,80	52 314 000 52 316 000
					
Lowering head ES 	10,19	52 202 100	End - shutter support for slab 	1,73	52 312 000
					
Crown head 	2,87	52 204 100	Rafter plate 	right 0,09 left 0,09	52 306 100 52 308 100
					
Crown head light 	1,51	52 206 100	Guide rail clamp 	12,40	52 400 100
					
Support head 	0,78	52 208 100			









Item	[kg]	Article n°	Item	[kg]	Article n°
Handrail post 	12,58	52 402 100			
					
Wind bracing 	7.00m	17,47	73 114 100		
					
Mobile scaffolding  Working height upon request		98 100 000			
					
H20 beam 	1.45m 7,25 1.80m 9,00 1.95m 9,75 2.15m 10,75 2.45m 12,25 2.65m 13,25 2.90m 14,50 3.30m 16,50 3.60m 18,00 3.90m 19,50 4.50m 22,50 4.90m 24,50 5.90m 29,50	91 145 500 91 180 500 91 195 500 91 215 500 91 245 500 91 265 500 91 290 500 91 330 500 91 360 500 91 390 500 91 450 500 91 490 500 91 590 500			
Beam fork Variflex 	1,47	52 500 600			
					

Table formwork VARITABLE

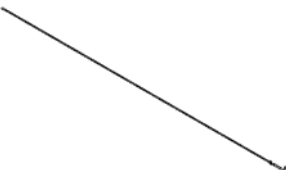
Efficient and cost-effective formwork system for execution of large-area slab projects.

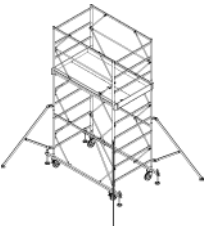
Varitable by Variant is a fast and efficient way of forming large-area slabs. The system can be easily adjusted to various structural and architectural designs (loads, shapes, concrete surface, etc.). Once assembled, a complete table unit can be positioned, adjusted, stripped and repositioned to a new area of concrete placement with minimal efforts. The table can be shifted along the slab using Variant shifting trolley. In order to gain maximum efficiency, Varitable can be easily combined with Varitable plus and Variflex systems.

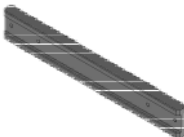
Load-bearing capacity:

- Due to its load-bearing flexibility, Varitable system can be adapted to bear loads of fresh concrete with the use of slabs of various thicknesses. It provides for optimal and cost-effective use within a range of slab thicknesses of up to 500 mm;
- Maximum table form height is 6.0 m.

System adaptability:

- It can be easily combined with Varitable Plus and Variflex systems;
- Any type of form-facing can be selected.

Easy handling and planning:

- Any architectural requirements for design of flat concrete slabs can be met;
- Can cover a wide range of practical applications.

Cost-effective:

- Rapid pace of work and cutting of re-assembly costs, due to repositioning of complete units;
- Table form can be horizontally repositioned without crane;
- The use of fewer elements speeds up assembly process;
- High number of use cycles results in lower follow-up expenses;
- Reduction of expenses by means of system adaptability;
- Galvanized or powder coated props for long service life.

Safe use:

- Such accessories as working platforms make the system handling safer and easier;
- Safe processing during assembly.





VARITABLE— system overview

Main features of the system:

- Assembled form components of the Variflex system;
- 4 standard formats: 2.50x4.00 m / 2.50x5.00 m / 2.00x4.00 m / 2.00x5.00 m;
- Maximum slab height up to 6.00 m;
- Wedge-lock of the table head makes prop mounting and dismounting easier;
- Pre-assembled table grille is used for facing with any desired form-ply.



Fitting intermediate props

Intermediate props are mainly required where the tables should be adapted for greater slab thickness (increased slab loads). The main props of the table (at least 4 of them must always be attached with a table head).

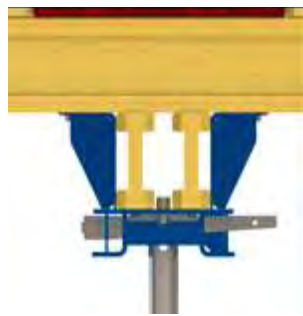
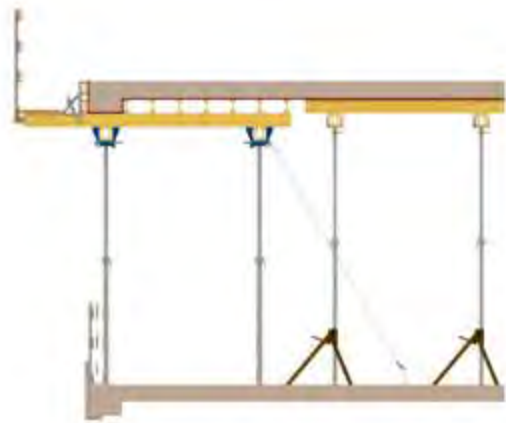

Table head Varitable firmly links double H20 primary beams of the table to the props.

Intermediate head Varitable firmly links the intermediate props to double H20 primary beams.



VARITABLE – tables placed around the edge of a slab



Varitable system for edge zones of a slab can be assembled in such a way to make drop-beam or stop-end casting easier with all the features integrated in one system.

There is a risk of edge-tables topping over due to cantilevering platforms. Moreover, stop-end formwork and drop beams cause horizontal forces acting in the direction of the slab edges. For this reason, all the edge tables must be secured with a suitable tie-back fixed to each primary beam.



VARITABLE – table shifting and repositioning

Horizontal shifting

Shifting trolley is used for shifting the table forms along the firm and flat surface in order to deliver them to an installation zone or to a zone for further vertical repositioning by a crane. Fine adjustment of the table form in an installation zone without use of a crane is possible.







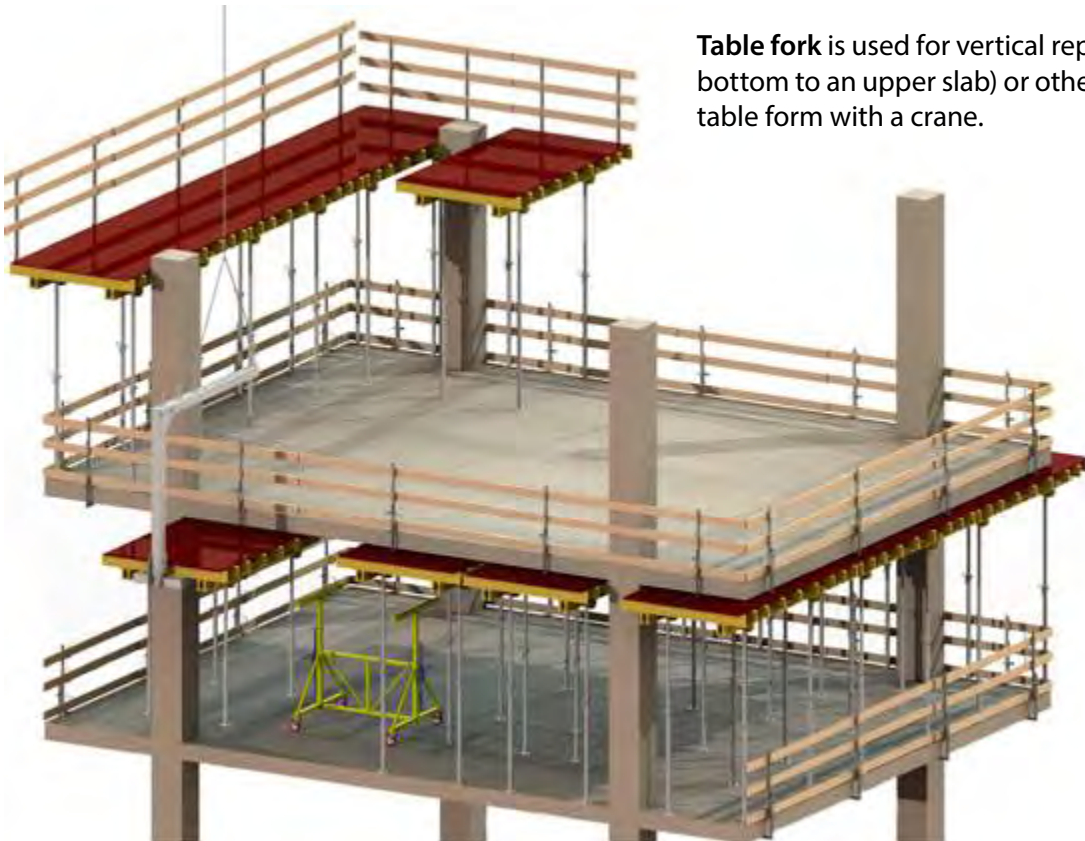





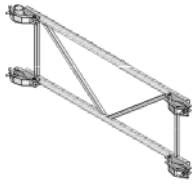



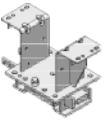





Vertical repositioning

Table fork is used for vertical repositioning (from a bottom to an upper slab) or other relocation of the table form with a crane.



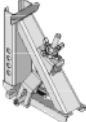

VARITABLE

Item		[kg]	Article n°	Item		[kg]	Article n°
Heavy duty prop RBGU  Options available: xx xxx 000 - Powder coated xx xxx 200 - Hot dip galvanized Custom size on request	2.50m	17,29	51 125 000	Bracing frame 	1.50m	17,04	52 314 000
	3.00m	20,49	51 130 000		1.80m	18,80	52 316 000
	3.50m	22,66	51 135 000	End - shutter support for slab 		52 312 000	
	4.00m	24,84	51 140 000				
	4.50m	27,02	51 145 000				
	5.00m	29,20	51 150 000				
	5.50m	31,36	51 155 000				
							
Table head Varitable 		19,74	53 200 000	Rafter plate 	right left	0,09 0,09	52 306 100 52 308 100
							
Intermediate head Varitable 		3,43	53 202 100	Guide rail clamp 		12,40	52 400 100
							
Connection unit Varitable 		1,05	53 204 100	Handrail post 		12,85	52 402 100
							
Beam screw 	60 110	0,07 0,09	23 302 100 23 304 100	Lifting hook Varitable 		6,17	53 500 100
							
Beam forming support 		7,77	52 302 000	Extension for beam forming support 		3,83	52 304 100
							











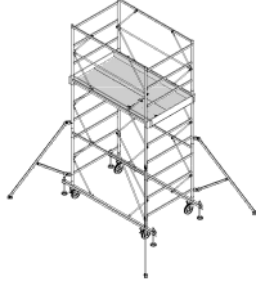

Item	[kg]	Article n°	Item	[kg]	Article n°
Transport fork 1t  0.93m 1.31m 2.03m 	545,16 567,32 601,97	53 502 000 53 504 000 53 506 000	Mobile scaffolding  working height upon request 		98 100 100
Transport fork' vertical extension  	185,6	53 508 000	H20 beam  1.95m 2.15m 2.45m 2.65m 2.90m 3.30m 3.60m 3.90m 4.50m 4.90m 5.90m	9,75 10,75 12,25 13,25 14,50 16,50 18,00 19,50 22,50 24,50 29,50	91 195 500 91 215 500 91 245 500 91 265 500 91 290 500 91 330 500 91 360 500 91 390 500 91 450 500 91 490 500 91 590 500
Shifting trolley Varitable  2.85m 3.60m 	264,81 281,61	53 510 000 53 512 000			
Stacking frame Varitable  1.95x1.86x1.80m 1.95x1.86x1.20m 1.95x1.86x0.90m 	196,18 131,57 120,75	53 514 000 53 516 000 53 518 000			
Wind bracing  7.00m 	17,47	73 114 100			

Table formwork VARITABLE PLUS

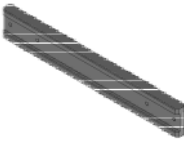
Even more efficient and cost-effective formwork system for large-area slab casting.

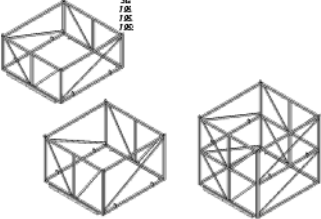
Varitable Plus by Variant is a fast and efficient way to form large-area slabs. The system can be easily adjusted to various structural and architectural designs (loads, shapes, concrete surfaces, etc.) Once assembled, a complete table unit can be positioned, adjusted, stripped and repositioned to a new area of concrete placement with minimal efforts. The table can be shifted along the slab using Variant shifting trolley. In order to gain maximum efficiency, Varitable Plus can be easily combined with Varitable and Variflex systems.

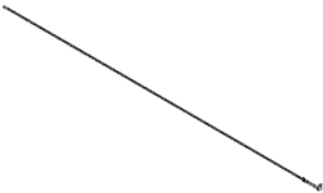
Consisting of such high-grade system components as waling 12 (as main beams) and H20 beams (as secondary beams), Varitable Plus system has several distinctive features compared to Varitable system:

- Higher load bearing capacity;
- Faster and simpler assembly;
- Integrable working platforms;
- System solutions for forming drop beams and stop-ends;
- Swivel-heads make the process of table moving out over parapets easier.

Load-bearing capacity:

- Due to its load-bearing flexibility, Varitable plus system can be adapted to bear loads of fresh concrete with the use of slabs of various thicknesses. It provides for optimal and cost-effective use within a range of slab thicknesses of up to 500 mm;
- Maximum table form height is 6.0 m.

System adaptability:

- It can be easily combined with Varitable and Variflex systems;
- Any type of form-facing can be selected.

Cost-effective:

- Rapid pace of work and cutting of assembly costs due to the repositioning of complete units;
- Outer drop beam and slab can be formed using one system;
- Table form can be horizontally repositioned without crane;
- The use of fewer elements speeds up assembly process;
- High number of use cycles results in lower follow-up expenses;
- Reduction of expenses by means of system adaptability.

Easy handling and planning:

- Any architectural requirements for concrete flat slab design can be met;
- Can cover a wide range of practical applications.

Safe use:

- Integrated working platforms for safe and easier system handling;
- Safe processing during assembly.





VARITABLE PLUS – system overview

Main features of the system:

- Higher load bearing capacity compared to Varitable system;
- It consists of such high-grate system components as waling 12 (as main beams) and H20 beams (as secondary beams);
- 4 standard formats: 2.50x4.00 m / 2.50x5.00 m / 2.00x4.00 m / 2.00x5.00 m;
- Maximum slab height is up to 6.00 m;
- The tilting mechanism of the swivel head enables prop folding and fixing at an angle of either 75 or 90 degrees for lifting tables out across parapets and railings;
- The swivel head is easy to relocate along primary beam;
- Wedge-lock of the swivel head makes prop mounting and dismounting easier;
- Pre-assembled table grille is used for facing with any desired form-ply.



Fitting intermediate props

Intermediate props are mainly required where the tables have to be adapted for greater slab thickness (increased slab loads). The main props of the table (at least 4 of them) should always be attached with a table head.



Swivel head Varitable plus firmly links steel primary table beams to the props.



Intermediate head Varitable plus firmly links the intermediate props to steel primary beams.

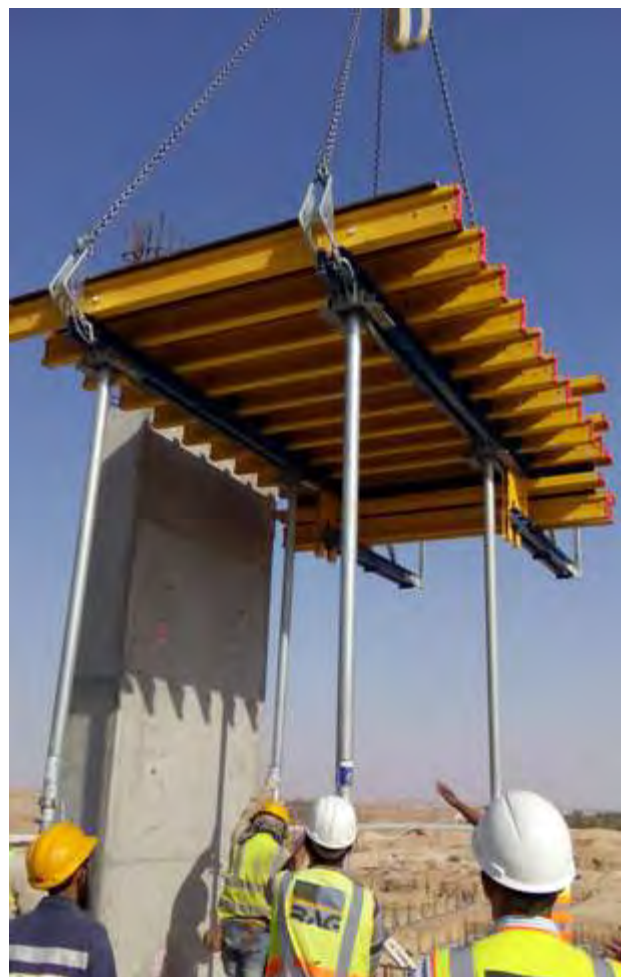

VARITABLE PLUS – tables installed around the edge of a slab

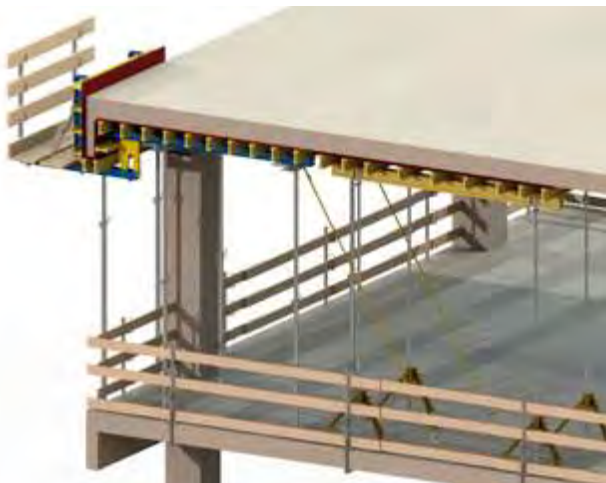

Varitable plus system for edge zones of a slab can be assembled in such a way to simplify drop-beam or stop-end casting with all the features integrated in one system.

There is a risk of edge-table topping over due to cantilevering platforms. Moreover, stop-end formwork and drop beams cause horizontal forces acting in the direction of the slab edges. For this reason, all the edge tables must be secured with a suitable tie-back fixed to each primary beam.



VARITABLE PLUS – table shifting and repositioning

Horizontal shifting











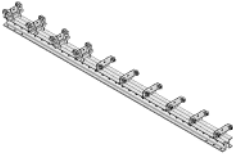

Shifting trolley is used for shifting the table forms along the firm and flat surface in order to deliver them to an installation zone or to a zone for further vertical repositioning by a crane. Fine adjustment of the table form in an installation zone without use of a crane is possible.



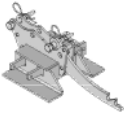



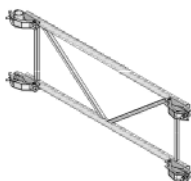





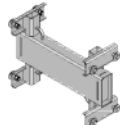









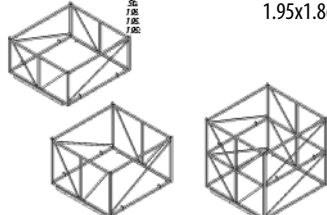

Vertical repositioning

Table fork is used for vertical repositioning (from a bottom to an upper slab) or other relocation of the table form with a crane.

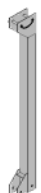

Item	[kg]	Article n°	Item	[kg]	Article n°	
Heavy duty prop RBGU  Options available: xx xxx 000 - Powder coated xx xxx 200 - Hot dip galvanized Custom size on request	2.50m	17,29	Spindle strut T6  ISO 3834	1.00-1.50m	19,01	54 308 100
	3.00m	20,49				
	3.50m	22,66				
	4.00m	24,84				
	4.50m	27,02				
	5.00m	29,20				
	5.50m	31,36				
Waling 12 Varitable plus 	3.50m	94,01	Spring locked connection pin 16 mm 		0,23	52 310 100
	4.00m	107,40				
	5.00m	134,30				
Waling 12 modifie 	2.00m	42,10	Flange clamp 		1,16	23 300 100
		56 200 000				
Swivel head Varitable plus 		16,07	Connecting pin 		0,39	23 400 100
		54 200 100				
Intermediate head Varitable plus 		1,04	Spring cotter 		0,05	23 402 100
		54 202 100				
Drop beam plate Varitable plus 	0.60m	24,75	Bracing frame 	1.50m 1.80m	17,04 18,80	52 314 000 52 316 000
	0.80m	32,24				
Connection angle Varitable plus 		2,98	End - shutter support for slab 		1,73	52 312 000
		54 302 100				

VARITABLE PLUS

Item		[kg]	Article n°	Item	[kg]	Article n°
Rafter plate	right left	0,09 0,09	52 306 100 52 308 100	Extension profile H20 Varitable plus	44,70	54 306 000
						
Guide rail clamp		12,40	52 400 100	Extension clamp H20 Varitable plus	6,13	54 304 000
						
Handrail post		12,85	52 402 100	Shifting trolley Varitable	2.85m 3.60m	264,81 281,61
						
Beam forming support		7,77	52 302 000	Stacking frame Varitable	1.95x1.86x1.80m 1.95x1.86x1.20m 1.95x1.86x0.90m	196,18 131,57 120,75
						
Transport fork 1t	0.93m 1.31m 2.03m	545,16 567,32 601,97	53 502 000 53 504 000 53 506 000	Table strut 340	23,80	54 314 100
						
Transport fork' vertical extension		185,60	53 508 000	Table strut 540	44,80	54 316 100
						

VARIANT

**YOU CAN RELY
ON US**

Slab props

Conventional solutions for fast and efficient slab forming.

Variant slab props are convenient and cost-effective solution for slab forming. Installation and dismantling requires minimal manpower during routine work on the site. The anti-handtrap and anti-dropout safeguard, forged nut, Galvanized finish and ergonomically shaped fastening clamp are just a few of the features of these tubular steel props that have convinced customers all over the world. Depending on your construction conditions (load of fresh concrete, formwork height, etc.) you can choose the system that suits your construction needs the best.

Heavy duty prop RBGU:

- Maximum load-bearing capacity: 25 kN of vertical load (for more detailed information on load-bearing capacity see section "Heavy duty prop RBGU - Item overview");
- Self-cleaning exposed thread;
- Possible formwork height depending on the prop height ranges from 0.97 to 5.50 m.

Medium duty prop RBGN:

- Maximum load-bearing capacity: 20 kN of vertical load (for more detailed information on load-bearing capacity see section "Medium duty prop RBGN - Item overview");
- Self-cleaning exposed thread;
- Possible formwork height depending on the prop height ranges from 1.46 to 5.00 m.

Medium duty prop RBG:

- Maximum load-bearing capacity: 20 kN of vertical load (for more detailed information on load-bearing capacity see section "Medium duty prop RBG - Item overview");
- Closed thread;
- Possible formwork height depending on the prop height ranges from 1.46 to 5.00 m.

Light duty prop RBGE:

- Maximum load-bearing capacity: 14 kN of vertical load (for more detailed information on load-bearing capacity see section "Light duty prop RBGE - Item overview");
- Closed thread;
- Possible formwork height depending on the prop height ranges from 1.51 to 4.50 m.

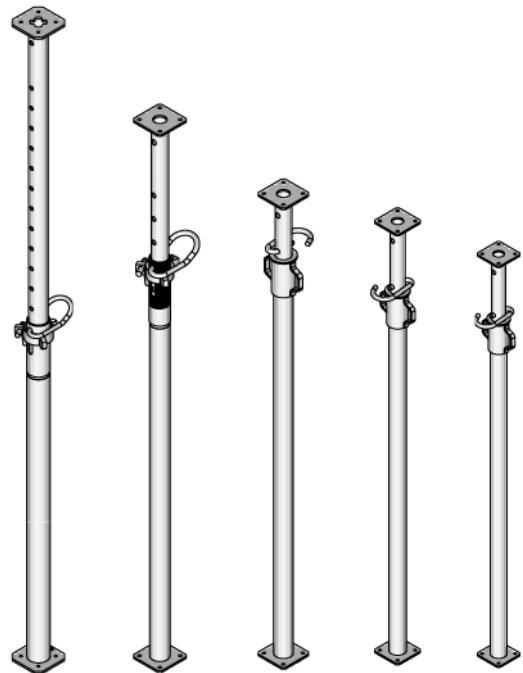



Heavy duty prop RBGU - Item overview

Main features:

- High load-bearing capacity;
- Pegging holes for easier height adjustment;
- Quick connection: various types of head adapters can be secured against pull with a spring pin;
- Dropout latch: for safety reasons, Variant slab props are latched to prevent the inner tube sliding out of the fixed tube;
- Special thread geometry making prop release easier even when it is under high load;
- Galvanized or powder coated for long service life.

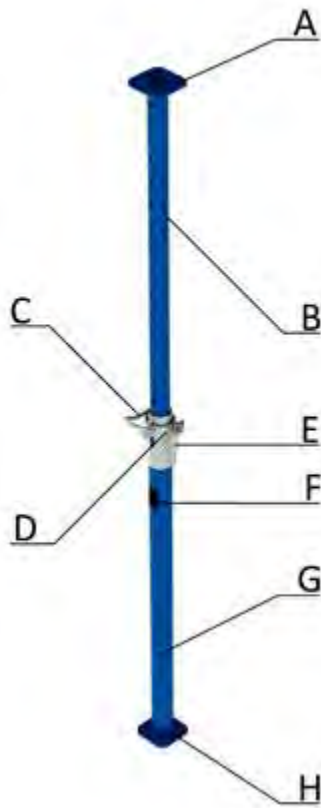

(A) Head plate
(B) Slider tube
(C) Open thread
(D) Peg
(E) Adjusting nut
(F) Type lable
(G) Fixed tube
(H) Baseplate

Permitted prop loads

Prop h., m	1.50	2.50	3.00	3.50	4.00	4.50	5.00	5.50
	Range of moving-out, m							
	0.96-1.50	1.52-2.54	1.97-3.04	2.22-3.54	2.47-4.04	2.72-4.54	2.97-5.04	3.22-5.54
5.5								
5.4								
5.3								
5.2								
5.1								
5.0								20kN
4.9								
4.8							20kN	
4.7								
4.6								
4.5								
4.4								
4.3								
4.2								
4.1								
4.0								
3.9								
3.8								
3.7								
3.6								
3.5								
3.4								
3.3								
3.2								
3.1								
3.0								
2.9								
2.8								
2.7								
2.6								
2.5								
2.4								
2.3								
2.2								
2.1								
2.0								
1.9								
1.8								
1.7								
1.6								
1.5								
0.9	25kN							

Medium duty prop RBGN - Item overview

Permitted prop loads

Prop h., m	2.50	3.00	3.50	4.00	4.50	5.00
	Range of moving-out, m					
	1.52-2.54	1.97-3.04	2.22-3.54	2.47-4.04	2.72-4.54	2.97-5.04
5.0						11kN
4.9						11.45kN
4.8						11.94kN
4.7						12.45kN
4.6						13kN
4.5					13.40kN	13.58kN
4.4					14.03kN	14.21kN
4.3					14.69kN	14.87kN
4.2					15.40kN	15.59kN
4.1					16.18kN	16.36kN
4.0				16kN	17.00kN	17.19kN
3.9				16.83kN	17.90kN	18.08kN
3.8				17.73kN	18.86kN	19.04kN
3.7				18.70kN		
3.6				19.75kN		
3.5						
3.4						
3.3						20kN
3.2					20kN	
3.1						
3.0				20kN		
2.9						
2.8			20kN			
2.7						
2.6						
2.5						
2.4		20kN				
2.3						
2.2						
2.1						
2.0	20kN					
1.9						
1.8						
1.7						
1.6						
1.5						

Main features:

- Medium load-bearing capacity;
- Pegging holes for easier height adjustment;
- Quick connection: various types of head adapters can be secured against pull with a spring pin;
- Dropout latch: for safety reasons, Variant slab props are latched to prevent the inner tube sliding out of the fixed tube;
- Special thread geometry making prop release easier even when it is under high load;
- Galvanized or powder coated for long service life.

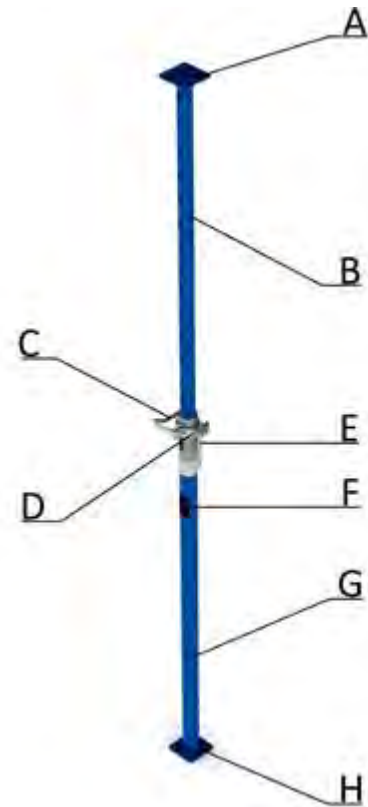

(A) Head plate

(B) Slider tube

(C) Open thread

(D) Peg

(E) Adjusting nut

(F) Type label

(G) Fixed tube

(H) Baseplate

Medium duty prop RBG - Item overview

Main features:

- Medium load-bearing capacity;
- Pegging holes for easier height adjustment;
- Quick connection: various types of head adapters can be secured against pull with a spring pin;
- Dropout latch: for safety reasons, Variant slab props are latched to prevent the inner tube sliding out of the fixed tube;
- Special thread geometry making prop release easier even when it is under high load;
- Galvanized or powder coated for long service life.

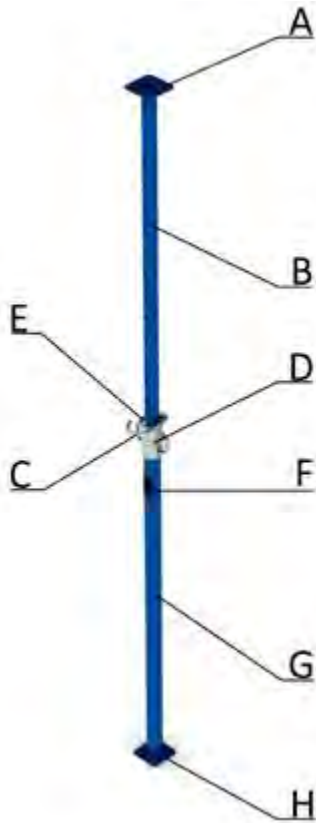

(A) Head plate
(B) Slider tube
(C) Open thread
(D) Peg
(E) Adjusting nut
(F) Type lable
(G) Fixed tube
(H) Baseplate

Permitted prop loads

Prop h., m	2.50	3.00	3.50	4.00	4.50	5.00
	Range of moving-out, m					
	1.52-2.54	1.97-3.04	2.22-3.54	2.47-4.04	2.72-4.54	2.97-5.04
5.0						9.58kN
4.9						9.97kN
4.8						10.39kN
4.7						10.84kN
4.6						11.32kN
4.5					11.20kN	11.82kN
4.4					11.50kN	12.37kN
4.3					12.27kN	12.95kN
4.2					12.86kN	13.58kN
4.1					13.49kN	14.25kN
4.0				13.20kN	14.17kN	14.97kN
3.9				13.88kN	14.91kN	15.67kN
3.8				14.63kN	15.70kN	16.59kN
3.7				15.43kN	16.57kN	17.50kN
3.6				16.30kN	17.50kN	18.49kN
3.5			14.50kN	17.25kN	18.52kN	19.56kN
3.4			15.37kN	18.94kN	19.62kN	20kN
3.3			16.31kN	19.40kN	20kN	
3.2			17.35	20kN		20kN
3.1			18.48kN		20kN	
3.0		20kN	20kN	20kN		20kN
2.9		20kN			20kN	
2.8			20kN	20kN		20kN
2.7		20kN			20kN	
2.6			20kN	20kN		20kN
2.5	20kN	20kN			20kN	
2.4	20kN		20kN	20kN		20kN
2.3		20kN			20kN	
2.2	20kN		20kN	20kN		20kN
2.1		20kN			20kN	
2.0	20kN		20kN	20kN		20kN
1.9		20kN			20kN	
1.8	20kN		20kN	20kN		20kN
1.7		20kN			20kN	
1.6	20kN		20kN	20kN		20kN
1.5		20kN			20kN	

Light duty prop RBGE - Item overview

Permitted prop loads

Prop h., m	2.50	3.00	3.50	4.00	4.50
	Range of moving-out, m				
	1.52-2.54	1.97-3.04	2.22-3.54	2.47-4.04	2.72-4.54
4.5					9.67kN
4.4					10.11kN
4.3					10.59kN
4.2					11.09kN
4.1					11.64kN
4.0				10.90kN	12.23kN
3.9				11.47kN	12.87kN
3.8				12.08kN	13.56kN
3.7				12.74kN	14.30kN
3.6				13.46kN	14.95kN
3.5			12kN	14.24kN	15kN
3.4			12.72kN	14.87kN	
3.3			13.50kN	15kN	
3.2			14.36kN		
3.1			15kN	15kN	
3.0		13kN			
2.9		13.91kN			
2.8		14.75kN			
2.7		15kN	15kN		
2.6					
2.5	14kN	15kN	15kN		
2.4	14.95kN				
2.3	15kN	15kN	15kN		
2.2					
2.1					
2.0					
1.9					
1.8					
1.7					
1.6					
1.5					

Main features:

- Light load-bearing capacity;
- Pegging holes for easier height adjustment;
- Quick connection: various types of head adapters can be secured against pull with a spring pin;
- Dropout latch: for safety reasons, Variant slab props are latched to prevent the inner tube sliding out of the fixed tube;
- Special thread geometry making prop release easier even when it is under high load;
- Galvanized or powder coated for long service life.

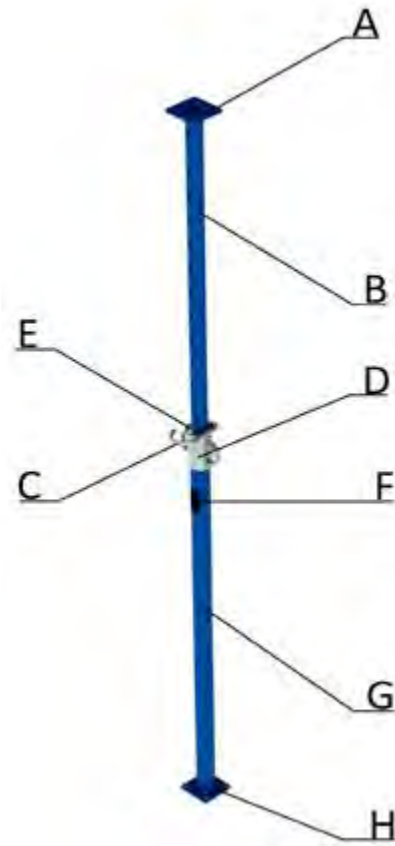

(A) Head plate

(B) Slider tube

(C) Open thread

(D) Peg

(E) Adjusting nut

(F) Type table

(G) Fixed tube

(H) Baseplate

Extra light duty prop RBR57 & RBR48 - Item overview

Main features:

- Extra light load-bearing capacity;
- Pegging holes for easier height adjustment;
- Quick connection: various types of head adapters can be secured against pull with a spring pin;
- Dropout latch: for safety reasons, Variant slab props are latched to prevent the inner tube sliding out of the fixed tube;
- Special thread geometry making prop release easier even when it is under high load;
- Galvanized or powder coated for long service life.

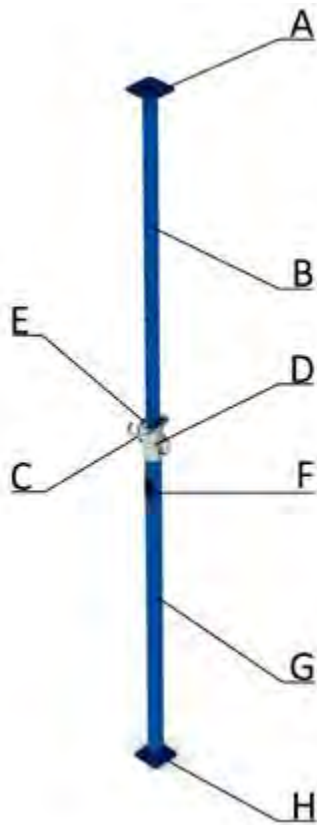













- | |
|-------------------|
| (A) Head plate |
| (B) Slider tube |
| (C) Peg |
| (D) Adjusting nut |
| (E) Toggle lever |
| (F) Type label |
| (G) Fixed tube |
| (H) Baseplate |

Permitted prop loads

Prop height, m	RBR57		RBR48	
	3.00 m	3.50 m	3.00 m	3.50 m
	Range of moving-out, m			
	1.71-3.05	1.96-3.55	1.71-3.05	1.96-3.55
3.5				
3.4				
3.3				
3.2				
3.1				
3.0				
2.9				
2.8				
2.7		10kN		8kN
2.6				
2.5				
2.4	10kN		8kN	
2.3				
2.2				
2.1				
2.0				
1.9				
1.8				
1.7				

Slab probs

Item	[kg]	Article n°	Item	[kg]	Article n°		
Heavv duty prop RBGU 	1.50m	13,45	51 115 000	Light duty prop RBGE 	2.50m	9,67	51 325 000
	2.50m	17,29	51 125 000		3.00m	10,97	51 330 000
	3.00m	20,49	51 130 000		3.50m	12,15	51 335 000
	3.50m	22,66	51 135 000		4.00m	13,45	51 340 000
	4.00m	24,84	51 140 000		4.50m	14,70	51 345 000
	4.50m	27,02	51 145 000				
	5.00m	29,20	51 150 000				
	5.50m	31,36	51 155 000				
							
Options available: xx xxx 000 - Powder coated xx xxx 200 - Hot dip galvanized Custom size on request			Options available: xx xxx 000 - Powder coated xx xxx 100 - Galvanized xx xxx 200 - Hot dip galvanized Custom size on request				
Medium duty prop RBGN 	2.50m	11,15	51 225 000	Extra light duty prop RBR 57 	3.00m	8,51	51 730 000
	3.00m	12,58	51 230 000		3.50m	9,56	51 735 000
	3.50m	14,16	51 235 000				
	4.00m	16,02	51 240 000				
	4.50m	17,45	51 245 000				
	4.50m	17,45	51 245 000				
	5.00m	18,88	51 250 000				
							
Options available: xx xxx 000 - Powder coated xx xxx 100 - Galvanized xx xxx 200 - Hot dip galvanized Custom size on request			Options available: xx xxx 000 - Powder coated xx xxx 100 - Galvanized xx xxx 200 - Hot dip galvanized Custom size on request				
Medium duty prop RBG 	2.50m	10,87	51 425 000	Extra light duty prop RBR 48 	3.00m	7,44	51 630 000
	3.00m	12,30	51 430 000		3.50m	8,24	51 635 000
	3.50m	13,55	51 435 000				
	4.00m	14,94	51 440 000				
	4.50m	16,38	51 445 000				
	4.50m	16,38	51 445 000				
	5.00m	17,80	51 450 000				
							
Options available: xx xxx 000 - Powder coated xx xxx 100 - Galvanized xx xxx 200 - Hot dip galvanized Custom size on request			Options available: xx xxx 000 - Powder coated xx xxx 100 - Galvanized xx xxx 200 - Hot dip galvanized Custom size on request				



VARIANT

**LOAD-
BEARING
SCAFFOLDING**

Load-bearing scaffolding TOP TOWER 40

The conventional shoring system for different applications.

The system of load-bearing scaffolding Top Tower 40 is based on robust frames made of galvanized or powder-coated steel with maximum load-bearing capacity of 40 kN per leg. The Top Tower 40 has a wide range of applications in bridge-building, high-rise and industrial construction fields. The system supports different kinds of slabs cast in place (thickness, heights, inclinations, etc.), Top Tower 40 is also used for shoring of precast elements. TT40 can be adjusted to different layouts and loads owing to variable inter-frame spacing. Assembly is easy, logical and fast, can be done by two workers. Individual adjustment of upper and lower supports is possible.

Load-bearing capacity:

- Load-bearing capacity is up to 40 kN per leg;
- The inter-frame spacing can vary in order to provide necessary load-bearing capacity.

System adaptability:

- Excellent adaptation to different layouts due to variable inter-frame spacing;
- Upper and lower supports with a 50 cm extension range each for easier height adjustment;
- The system can be precisely adjusted to any length, width and height.

Cost-effective:

- Rapid pace of work and cutting of assembly costs.
- The use of fewer elements speeds up assembly process;
- High number of use cycles results in lower follow-up expenses;
- Reduction of expenses by means of system adaptability;
- Galvanized or powder-coated frames for long service life.

Easy handling and planning:

- Small number of different parts is used;
- No tools are required for assembly;
- Any architectural requirements to concrete slab design can be met;
- Can cover a wide range of practical applications.

Safe use:

- It can be horizontally pre-assembled and safely lifted and installed vertically due to inter-frame connections;
- Dependable stability.





TOP TOWER 40 – system overview

(A) Upper support TT40

Upper height-adjustment spindle, which is used for structure support and redistribution of the loads on rigid scaffolding frames, provides 50 cm of adjustment length (up to 30 cm without bracing, from 30 up to 50 cm should be braced using frame tubes).

(B) Scaffold frame TT40

Rigid, galvanized or powder coated frames in three different heights are a basis of economical load-bearing tower designed for various applications.

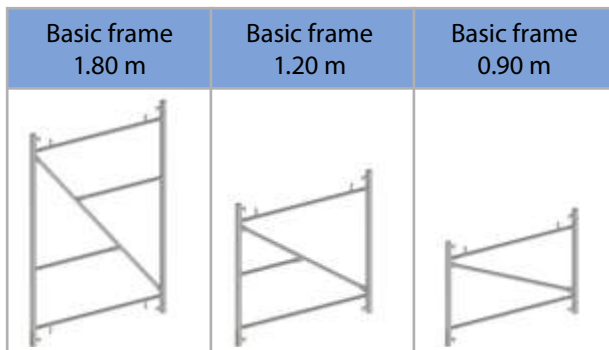

(C) Cross tie

Cross ties connect scaffolding frames horizontally and vertically, thus providing a stiff structure of guaranteed spatial rigidity. Changing inter-frame space by installation of cross ties with different sizes makes adjustment of the system to various layouts possible.

There are 3 standard tower dimensions achieved by horizontal and vertical installation of cross ties. Horizontal installation depends only on inter-frame spacing whereas vertical depends on inter-frame spacing and height of the frame used.



Tower 1.5x1.0 m

Top view

Horizontal cross
tie 1.2x1.0

Tower 1.5x1.5 m

Top view

Horizontal cross
tie 1.2x1.5

Tower 1.5x2.0 m

Top view

Horizontal cross tie
1.2x2.0

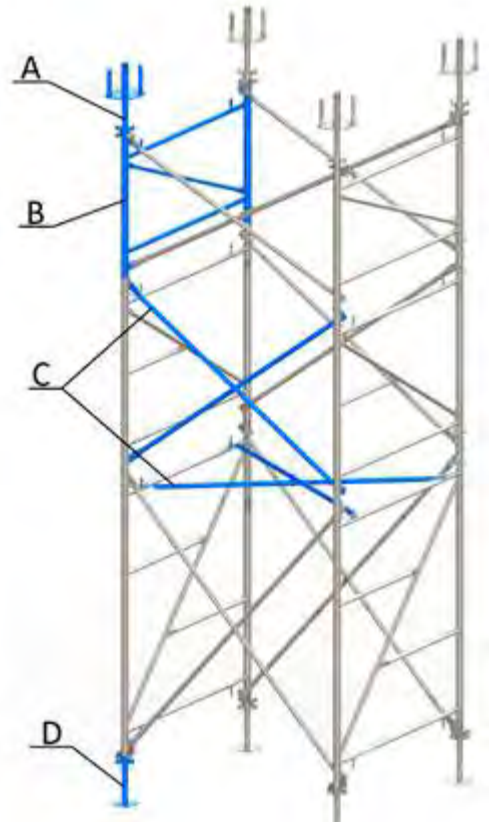

Cross ties used for making different towers Tower dimensions

Type of installation	1.5x1.0 m	1.5x1.5 m	1.5x2.0 m
Horizontal	1.2x1.0	1.2x1.5	1.2x2.0
Vertical			
<i>frame 0.9x1.5</i>	0.9x1.0	0.9x1.5	0.9x2.0
<i>frame 1.2x1.5</i>	1.2x1.0	1.2x1.5	1.2x2.0
<i>frame 1.8x1.5</i>	1.8x1.0	1.8x1.5	1.8x2.0

(D) Lower support TT40

Lower height-adjustment spindle, which is used for structure support and redistribution of the loads on rigid scaffolding frames, provides 50 cm of adjustment length (up to 30 cm without bracing, from 30 up to 50 cm should be braced using frame tubes).

TOP TOWER 40— interconnection



For reliable use and safe repositioning of assembled (pre-assembled) units by a crane Top Tower 40 has interconnection system. It consists of **insert TT40** installed between two frames and fixed by **retainers TT40** to each frame.

TOP TOWER 40— repositioning

















Assembled (pre-assembled) Top Tower 40 unit can be wheeled to the next location, quickly and easily, using a **wheel unit**.

The wheel unit can perform the following functions:











- Lifting;
- Wheeling;
- Lining-and-leveling;
- Lowering.



TOP TOWER 40

Item		[kg]	Article n°	Item		[kg]	Article n°
Scaffold frame TT40  Options available: xx xxx 000 - Powder coated xx xxx 200 - Hot dip galvanized Custom size on request	0.90x1.50m	14,56	61 110 000	Anti-dropout lock TT40  ISO 3834		0,59	61 404 100
	1.20x1.50m	18,22	61 120 000				
	1.80x1.50m	25,70	61 130 000				
				Framed tube  ISO 3834	1.00m	4,60	94 100 200
					1.50m	6,91	94 150 200
					2.00m	9,21	94 200 200
					2.50m	11,51	94 250 200
					3.00m	13,81	94 300 200
Cross tie  Options available: xx xxx 000 - Powder coated xx xxx 200 - Hot dip galvanized Custom size on request	0.90x1.00m	4,08	61 210 000	Swivel coupler 48x48mm  ISO 3834		1,22	95 106 100
	1.20x1.00m	4,67	61 220 000				
	1.80x1.00m	6,06	61 230 000				
	0.90x1.50m	5,36	61 212 000				
	1.20x1.50m	5,86	61 222 000				
	1.80x1.50m	7,12	61 232 000				
	0.90x2.00m	6,79	61 214 000				
	1.20x2.00m	7,19	61 224 000				
	1.80x2.00m	8,24	61 234 000				
	0.90x2.50m	8,22	61 216 000				
	1.20x2.50m	8,56	61 226 000				
	1.80x2.50m	9,46	61 236 000	Screw-on coupler 48 mm  ISO 3834	30	1,21	95 100 100
					70	1,26	95 102 100
					100	1,33	95 104 100
Insert TT40 		0,89	61 400 100	Anchoring shoe  ISO 3834		5,03	61 800 100
Retainer TT40 		0,06	61 402 100	Clamping plate 		1,71	61 406 100
Upper support TT40  ISO 3834		13,86	61 500 100	Clamping tie-rod 330 		0,95	61 408 100
				Star - shaped nut 	15	0,40	95 206 100
Lower support TT40  ISO 3834		11,09	61 502 100	Beam screw 	60	0,07	23 302 100
					110	0,09	23 304 100

TOP TOWER 40

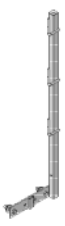
Item	[kg]	Article n°	Item	[kg]	Article n°
Drop beam forming support 	7,77	52 302 000	Mounting bridge TT40  1.00m 9,45 1.50m 13,76 2.00m 21,63	9,45 13,76 21,63	61 412 000 61 414 000 61 416 000
Extension for drop beam forming support 	3,83	52 304 100	Shifting wheel TT40 	47,46	61 600 000
End - shutter support for slab 	1,73	52 312 000	Tower strut TT40 340 	23,13	61 700 100
Rafter plate 	right 0,09 left 0,09	52 306 100 52 308 100	Tower strut TT40 540 	44,10	61 702 100
Tower bracket TT40 	16,28	61 410 000			
Handrail clamp 	12,40	52 400 100			
Handrail post 	12,85	52 402 100			

Load-bearing scaffolding TOP TOWER 60

The medium-duty shoring system for different applications.

The system of load-bearing scaffoldings Top Tower 60 is based on robust frames made of galvanized or powder-coated steel with maximum load-bearing capacity of 60 kN per leg. The Top Tower 60 has a wide range of applications in bridge-building, high-rise and industrial construction fields. The system supports different kinds of slabs cast in place (thickness, heights, inclinations, etc.), Top Tower 60 is also used for shoring of precast elements. TT60 can be adjusted to different layouts and loads owing to variable inter-frame spacing. Assembly is easy, logical and fast, can be done by two workers. Individual adjustment of upper and lower supports is possible.

Load-bearing capacity :

- Load-bearing capacity is up to 60 kN per leg;
- The inter-frame spacing can vary in order to provide necessary load-bearing capacity.

System adaptability:

- Excellent adaptation to different layouts due to variable inter-frame spacing;
- Upper and lower supports with a 50 cm extension range each for easier height adjustment;
- The system can be precisely adjusted to any length, width and height.

Cost-effective:

- Rapid pace of work and cutting of assembly costs;
- The use of fewer elements speeds up assembly process;
- High number of use cycles results in lower follow-up expenses;
- Reduction of expenses by means of system adaptability;
- Galvanized or powder-coated frames for long service life.

Easy handling and planning:

- Small number of different parts is used;
- No tools are required for assembly;
- Any architectural requirements to concrete slab design can be met;
- Can cover a wide range of practical applications.

Safe use:

- It can be horizontally pre-assembled and safely lifted and installed vertically due to inter-frame connections;
- Dependable stability.

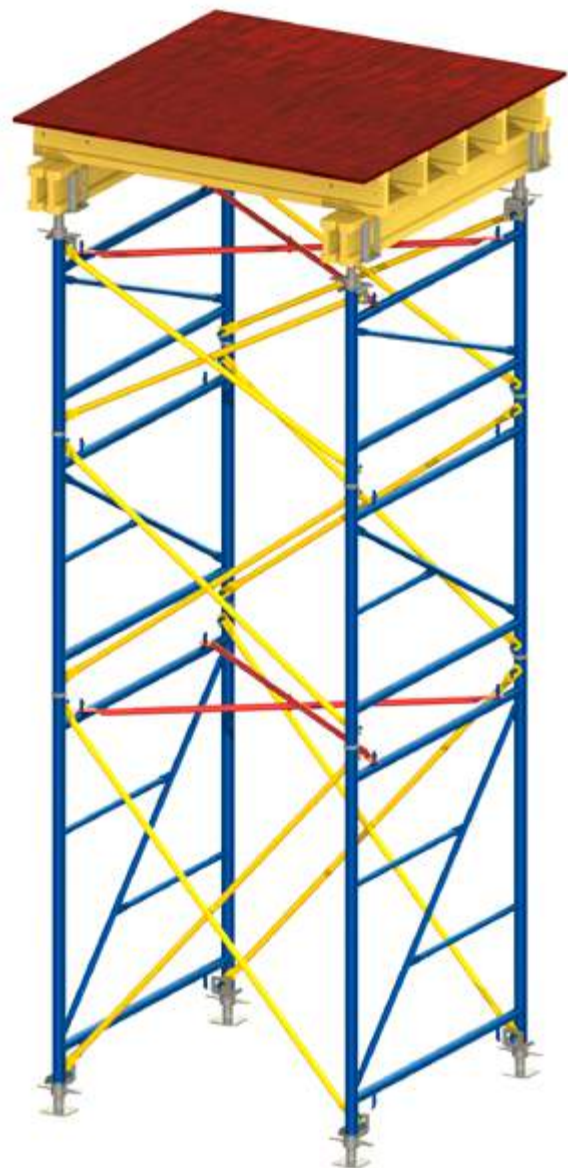





TOP TOWER 60 – system overview

(A) Upper support TT60

Upper height-adjustment spindle, which is used for structure support and redistribution of the loads on rigid scaffolding frames, provides 50 cm of adjustment length (up to 30 cm without bracing, from 30 up to 50 cm should be braced using frame tubes).

(B) Scaffold frame TT60

Basic frame 1.80 m	Basic frame 1.20 m	Basic frame 0.90 m
		

(C) Cross tie

Cross ties connect scaffolding frames horizontally and vertically, thus providing a stiff structure of guaranteed spatial rigidity. Changing inter-frame space by installation of cross ties with different sizes makes adjustment of the system to various layouts possible.

There are 3 standard tower dimensions achieved by horizontal and vertical installation of cross ties. Horizontal installation depends only on inter-frame spacing whereas vertical depends on inter-frame spacing and height of the frame used.

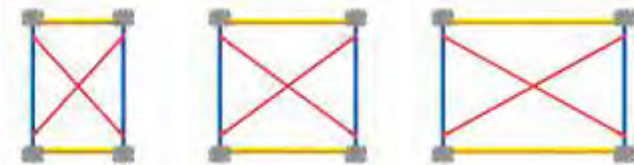

Tower 1.5x1.0 m
Top view

Horizontal cross tie
1.2x1.0

Tower 1.5x1.5 m
Top view

Horizontal cross tie
1.2x1.5

Tower 1.5x2.0 m
Top view

Horizontal cross tie
1.2x2.0

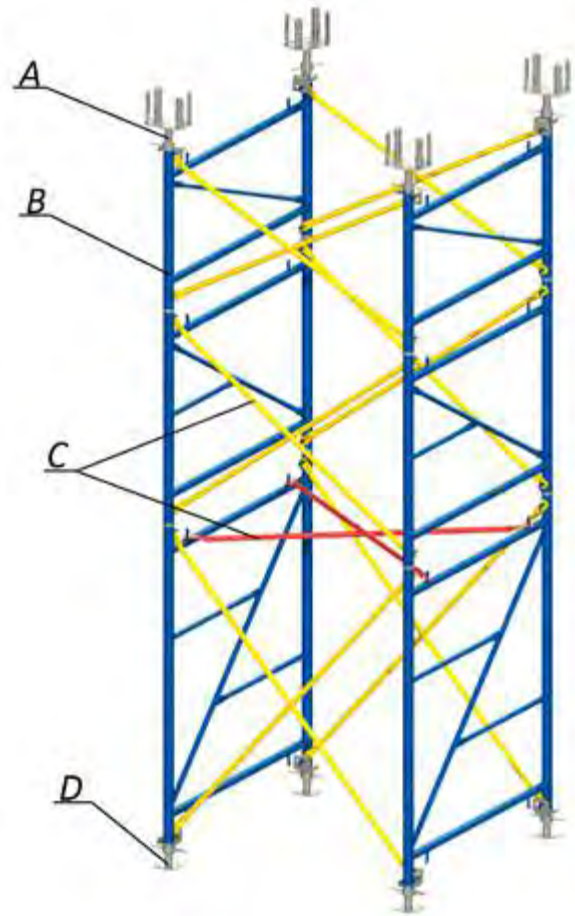

Cross ties used for different tower creation Tower dimensions

Type of installation	1.5x1.0 m	1.5x1.5 m	1.5x2.0 m
Horizontal	1.2x1.0	1.2x1.5	1.2x2.0
Vertical			
frame 0.9x1.5	0.9x1.0	0.9x1.5	0.9x2.0
frame 1.2x1.5	1.2x1.0	1.2x1.5	1.2x2.0
frame 1.8x1.5	1.8x1.0	1.8x1.5	1.8x2.0

(D) Lower support TT60

Lower height-adjustment spindle, which is used for structure support and redistribution of the loads on rigid scaffolding frames, provides 50 cm of adjustment length (up to 30 cm without bracing, from 30 up to 50 cm should be braced using frame tubes).

TOP TOWER 60— interconnection



For reliable use and safe repositioning of assembled (pre-assembled) units by a crane Top Tower 60 has interconnection system. It consists of insert TT60 installed between two frames and fixed by retainers TT60 to each frame.

TOP TOWER 60— repositioning

















Assembled (pre-assembled) Top Tower 60 unit can be wheeled to the next location, quickly and easily, using a wheel unit.

The wheel unit can perform the following functions:











- Lifting;
- Wheeling;
- Lining-and-leveling;
- Lowering.



TOP TOWER 60

Item		[kg]	Article n°	Item		[kg]	Article n°
Scaffold frame TT60  Options available: xx xxx 000 - Powder coated xx xxx 200 - Hot dip galvanized Custom size on request	0.90x1.50m	20,49	62 110 000	Anti-dropout lock TT60  ISO 3834		0,68	62 404 100
	1.20x1.50m	24,77	62 120 000				
	1.80x1.50m	33,56	62 130 000				
				Framed tube  1.00m 4,60 94 100 200 1.50m 6,91 94 150 200 2.00m 9,21 94 200 200 2.50m 11,51 94 250 200 3.00m 13,81 94 300 200			
Cross tie  Options available: xx xxx 000 - Powder coated xx xxx 200 - Hot dip galvanized Custom size on request	0.90x1.00m	4,08	61 210 000	Swivel coupler  48x48mm 1,22 95 106 100 60x48mm 1,47 95 108 100			
	1.20x1.00m	4,67	61 220 000				
	1.80x1.00m	6,06	61 230 000				
	0.90x1.50m	5,36	61 212 000				
	1.20x1.50m	5,86	61 222 000				
	1.80x1.50m	7,12	61 232 000				
	0.90x2.00m	6,79	61 214 000				
	1.20x2.00m	7,19	61 224 000				
	1.80x2.00m	8,24	61 234 000				
	0.90x2.50m	8,22	61 216 000		Screw-on coupler 48 mm  30 1,21 95 100 100 70 1,26 95 102 100 100 1,33 95 104 100 ISO 3834		
1.20x2.50m	8,56	61 226 000					
1.80x2.50m	9,46	61 236 000					
Insert TT60 		1,19	62 400 100	Anchoring shoe  ISO 3834		5,03	61 800 100
Retainer TT60 		0,07	62 402 100	Clamping plate 		1,71	61 406 100
Upper support TT60  ISO 3834		16,80	62 500 100	Clamping tie-rod 330  0,95 61 408 100			
				Star - shaped nut  15 0,40 95 206 100			
Lower support TT60  ISO 3834		14,06	62 502 100	Beam screw  60 0,07 23 302 100 110 0,09 23 304 100			

TOP TOWER 60

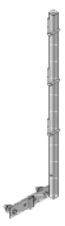
Item	[kg]	Article n°	Item	[kg]	Article n°
Drop beam forming support 	7,77	52 302 000	Mounting bridge TT40 	1.00m 9,45 1.50m 13,76 2.00m 21,63	61 412 000 61 414 000 61 416 000
Extension for drop beam forming support 	3,83	52 304 100	Shifting wheel TT40 	47,46	61 600 000
End - shutter support for slab 	1,73	52 312 000	Tower strut TT60 340 	23,13	61 700 100
Rafter plate 	right 0,09 left 0,09	52 306 100 52 308 100	Tower strut TT60 540 	44,10	61 702 100
Tower bracket TT40 	16,28	61 410 000			
Handrail clamp 	12,40	52 400 100			
Handrail post 	12,85	52 402 100			

Load-bearing scaffolding TOP TOWER 100

Heavy-duty system for high shoring and heavy loads.

Top Tower 100 is a heavy-duty scaffolding system with a wide range of applications in bridge-building, high-rise and industrial construction. With a maximum load-bearing capacity of 100 kN per leg the system is mainly used for:

- Forming of different kinds of cast in place slabs e.g. flat and inclined;
- Shoring system for bridges superstructures e.g. precast or metal;
- Temporary support during complex installation works.

Top Tower 100 is a cost-saving shoring system for heavy loads, which suits best for construction of bridges, flyovers, overpasses, viaducts as well as other types of industrial projects.

Load-bearing capacity:

- Load bearing capacity is up to 100 kN per leg;
- Tower base can be anchored to the ground for load bearing capacity increase.

System adaptability:

- Versatile modular system for different shoring configurations;
- The system can be precisely adjusted to any length, width and height;
- Independent jacks for elevations.

Cost-effective:

- Quick and safe on-site erection;
- The use of fewer elements speeds up assembly process;
- High number of use cycles results in lower follow-up expenses;
- Reduction of expenses by means of system adaptability;
- Galvanized or powder-coated elements for long service life.

Easy handling and planning:

- Easy and secure joints between components;
- Any architectural requirements for concrete slab design can be met;
- Can cover a wide range of practical applications;
- Few elements for wide range of combinations.

Safe use:

- Platform and handrails can be installed at any point of the towers. Access stairs between towers;
- Dependable stability.

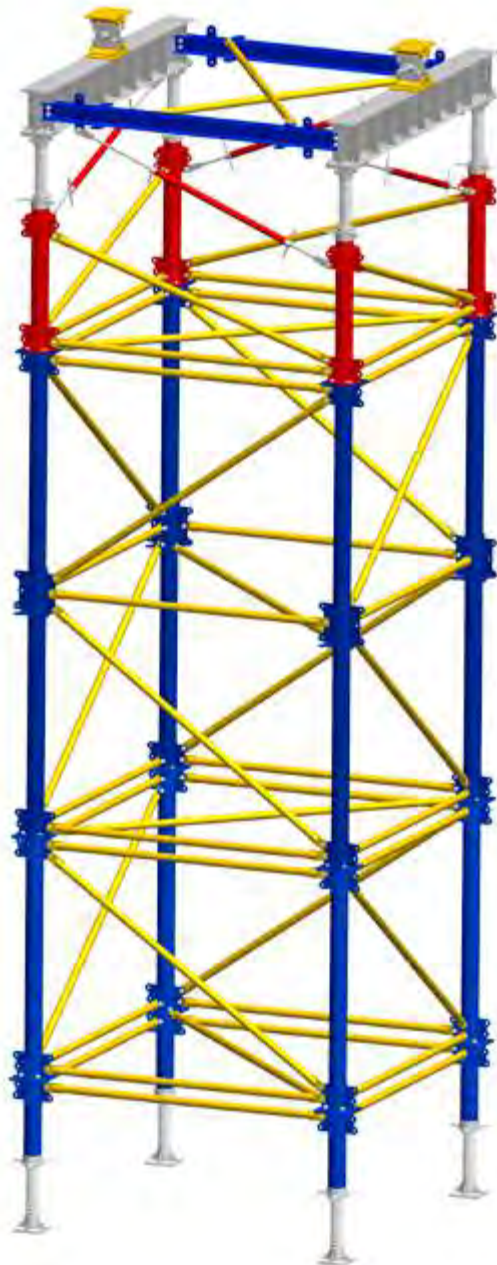

TOP TOWER 100 — system overview

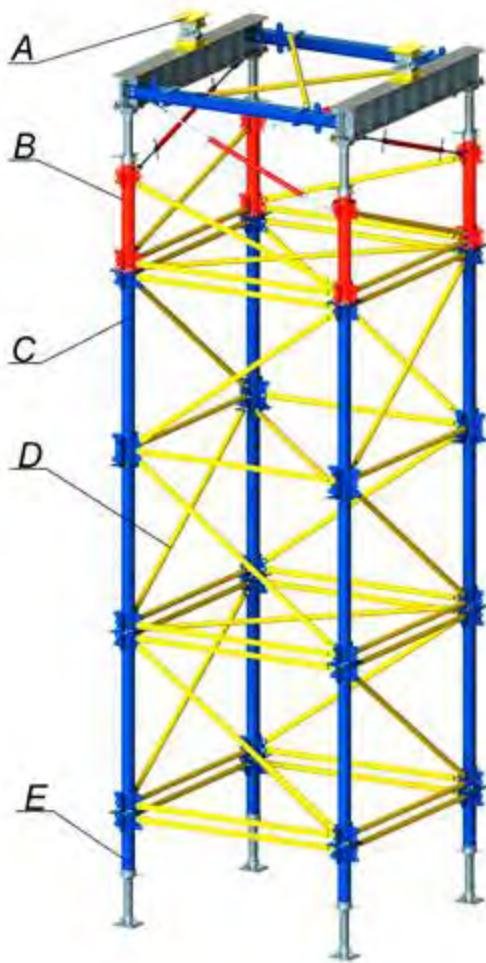

A) Wedge jack TT100

(B) Upper jack TT100

(C) Upright support TT100

(D) Diagonal brace TT100

(E) Base jack TT100

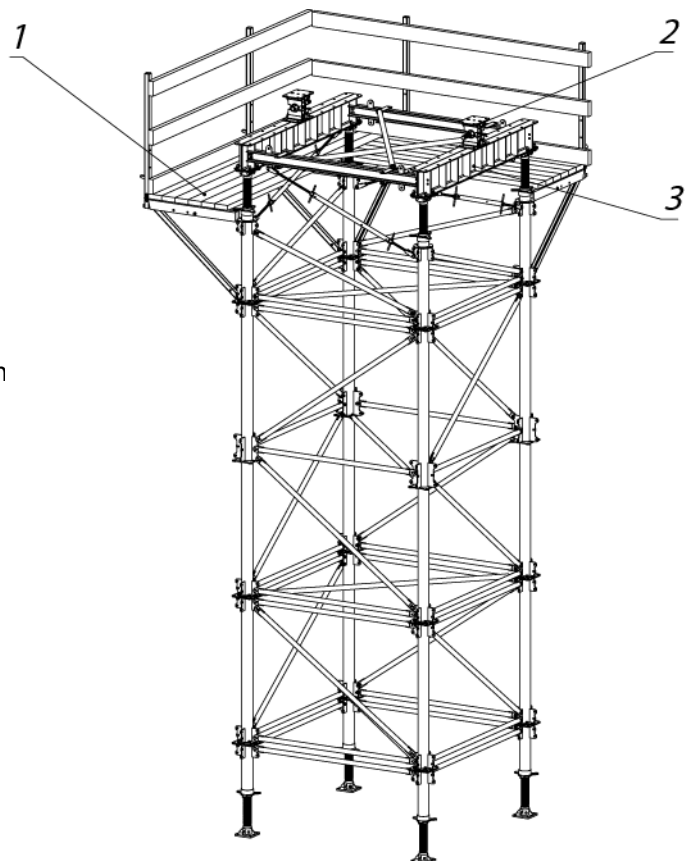







FEATURES



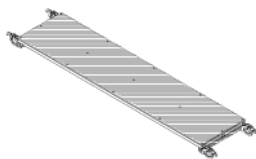
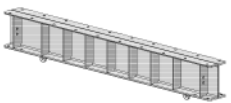

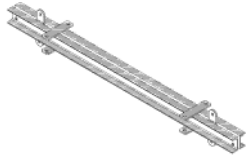
Module sizes of towers in top view: 2x2 m and 2x3 m

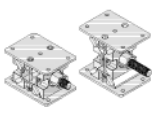
1. Working platform
2. Stripping system
3. Longitudinal beam TT100

TOP TOWER 100

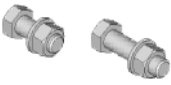
		[kg]	Article n°	Item	[kg]	Article n°
Upright support TT100  Options available: xx xxx 000 - Powder coated xx xxx 200 - Hot dip galvanized	1.50m	25,20	63 000	Tensioner TT100  Options available: xx xxx 000 - Powder coated xx xxx 200 - Hot dip galvanized	5,99	63 402 000
	3.00m	46,20	63 102 000		ISO 3834	ISO 3834
Diagonal brace TT100  Options available: xx xxx 000 - Powder coated xx xxx 200 - Hot dip galvanized	2.00-2.00m	8,19	63 200 000	Working platform TT100  Options available: xx xxx 000 - Powder coated xx xxx 200 - Hot dip galvanized	18,90	63 404 000
	2.00-1.50m	7,04	63 202 000		2.02x0.45m	22,05
	2.00-0.90m	6,20	63 204 000		ISO 3834	
Longitudinal beam TT100  Options available: xx xxx 000 - Powder coated xx xxx 200 - Hot dip galvanized	0.30x0.20x2.22m	194,25	63 300 000	Working platform with a hatch TT100  Options available: xx xxx 000 - Powder coated xx xxx 200 - Hot dip galvanized	28,35	63 408 000
	0.27x0.19x2.22m	157,50	63 302 000		2.02x0.63m	ISO 3834
Cross beam TT100  Options available: xx xxx 000 - Powder coated xx xxx 200 - Hot dip galvanized	0.10x0.11x1.96m	42,00	63 304 000	Ladder TT100  Options available: xx xxx 000 - Powder coated xx xxx 200 - Hot dip galvanized	8,72	63 410 000
					1.70m	ISO 3834
Tensioner TT100 2.0  Options available: xx xxx 000 - Powder coated xx xxx 200 - Hot dip galvanized		5,99	63 400 000	Wedge jack TT100  Options available: xx xxx 000 - Powder coated xx xxx 200 - Hot dip galvanized	42,00	63 412 000
					280x200x180mm	ISO 3834

TOP TOWER 100

		[kg]	Article n°	Item	[kg]	Article n°
Bolted connection 	BC1	0,15	63 414 100			
	BC2	0,18	63 416 100			
Base jack TT100 	0.65m	36,75	63 500 100			
	1.05m	44,10	63 502 100			
						
Upper jack TT100 	0.65m	35,70	63 504 100			
	1.05m	43,05	63 502 100			
						

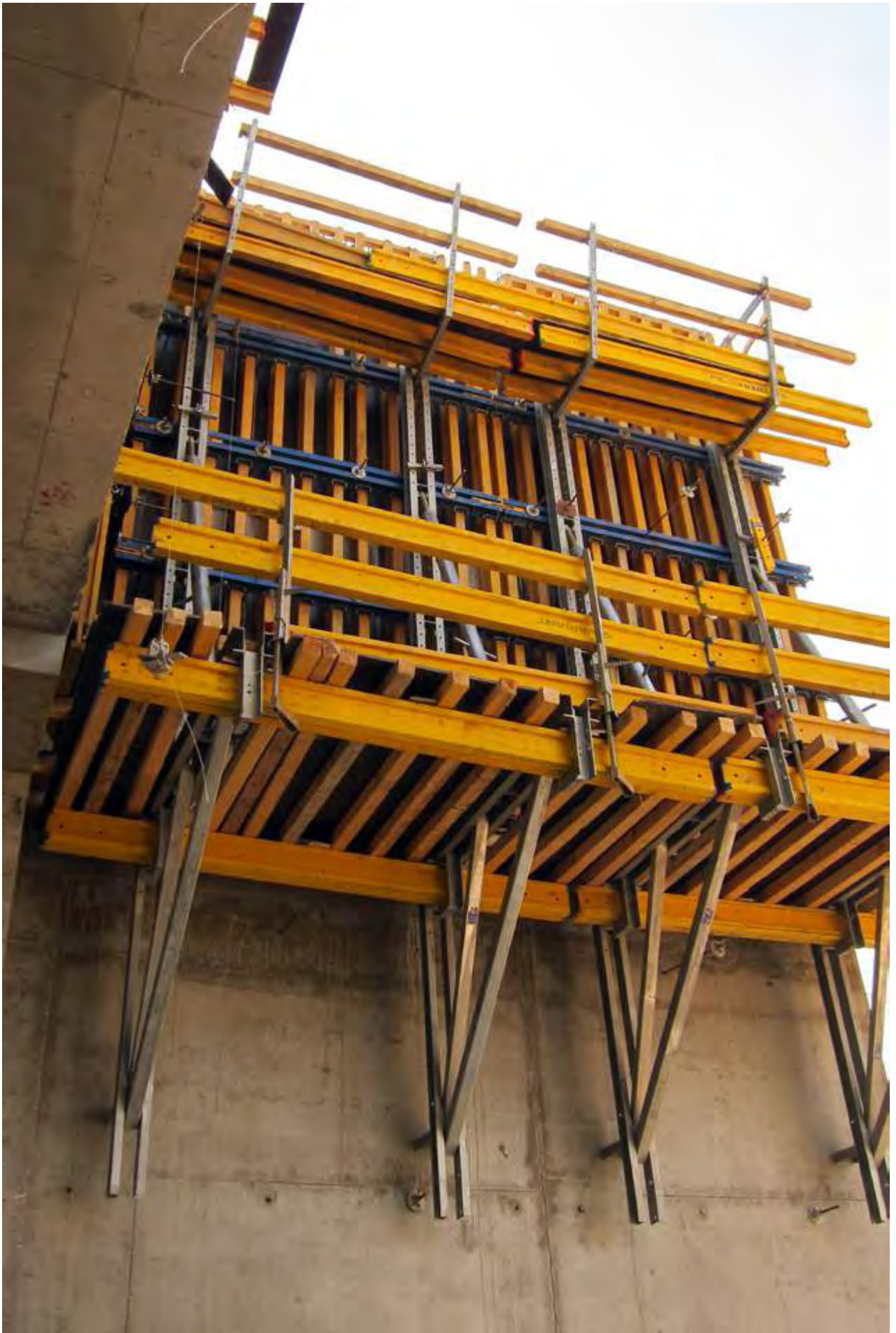

VARIANT

CLIMBING FORMWORK

Crane-climbing formwork system CCF

Crane-jumped formwork for applications of any shape and height.

The Variant crane-climbing formwork CCF can be easily set up and lifted by a crane. CCF provides for execution of controlled, regular working cycles on all structures such as high-rises, bridge piers and pylons. The system is simple to operate and work with wall inclinations of up to +/- 15 degree. Owing to its flexible modular structure CCF can be extended and upgraded in many ways. CCF is a highly flexible and cost-effective solution requiring only minimal crane use what makes it an ideal system solution for many high-rise applications. Crane-climbing formwork CCF can be easily used with framed or timber-beam formwork.

Load-bearing capacity:

- High load-bearing capacity (50 kN per climbing bracket);
- Formwork height of up to 6.0 m.

System adaptability:

- Excellent adaptability to any height, shape and inclination of a wall;
- Swift, precise formwork adjustment in all directions;
- Simple inclination adjustment.

Cost-effective:

- Small number of suspension points due to the bracket high load-bearing capacity;
- Less crane-time needed as the climbing brackets and formwork are moved up as a single unit.

Easy handling and planning:

- Small number of different parts is used;
- Integrated traveling units allow quick formwork closing and opening (retraction) up to 75 cm without crane use;
- Simple inclination adjustment;
- The formwork can be quickly and precisely plumbed and aligned in all directions using a simple adjustment mechanism;
- Any architectural requirements for concrete wall design can be met.

Safe use:

- Safe working conditions provided by 2.40 m fully railed-in working platform;
- Formwork can be rolled back 0.75 m thus leaving space for forming and reinforcing operations.



Crane-climbing formwork system CCF - System overview

Climbing platform (A) – pre-assembled modular element assembled of climbing brackets and decking. Working width of the platform (distance between wall and handrails) is 2.4 m.

Climbing bracket CCF (B) is a core of the system, it bears and transfers loads of fresh concrete and live load of working and pouring platforms acting on the anchoring points and structure.

Traveling gear CCF (C) – with a traveling gear an entire formwork panel can be easily moved forward/ backward (retracted) in order to simplify formwork striking.

Vertical waling CCF (D) – all types of wall formwork (e.g. large-area, framed) can be fixed to the climbing platform and traveling gear via vertical waling. Use of the vertical waling makes adjustment, alignment, retraction and reposition of formwork system as one unit possible.

Spindle strut CCF (E) is used for formwork alignment and/or adjustment of front or rear inclinations.







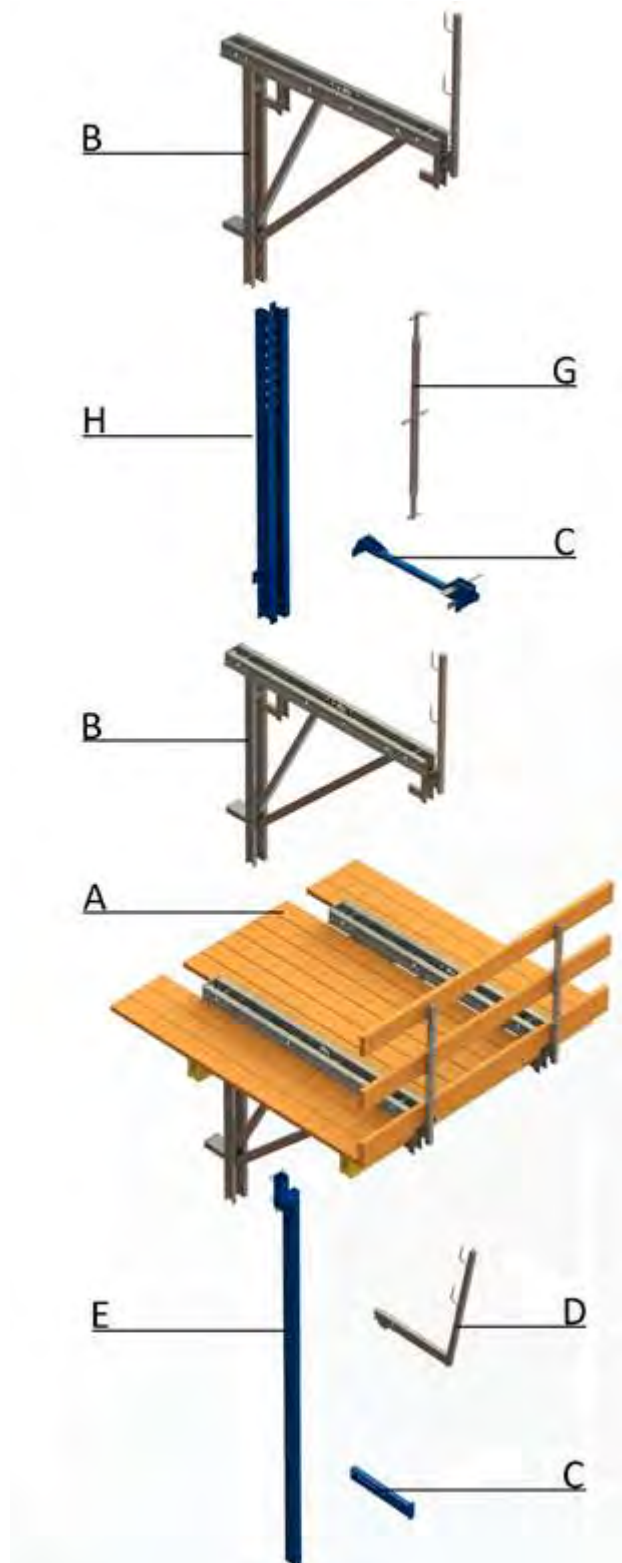



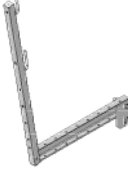





Suspension profile CCF (F) is fixed to the climbing bracket and used to transfer the load of suspension platform to the climbing bracket.

Screw-on access bracket (G) is used to make a pouring platform when fixed to the vertical waling (H). It also can be used as a suspension platform when fixed to the suspension profile (E).



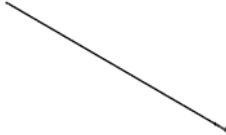

Distance profile CCF (H) is used as a support for suspended platform.



Crane-climbing formwork CCF

Item	[kg]	Article n°	Item	[kg]	Article n°	
Climbing bracket CCF 	188,86	75100200	Screw-on access bracket 	17,32	75 116 100	
Vertical waling CCF 	3.00m 79,23 4.50m 128,57 	75 104 200 75 106 200	Swivel plate 	4,10	75 118 100	
			Waling-to-bracket holder 	2,61	75 200 100	
Plumbing strut CCF 	3.00m 25,34 4.50m 49,98 	75 108 100 75 110 100	Framed tube 48 mm 	1.00m 4,60 1.50m 6,91 2.00m 9,21 2.50m 11,51 3.00m 13,81	94 100 200 94 150 200 94 200 200 94 250 200 94 300 200	
			Swivel coupler 	48x48mm	1,22	95 106 100
Travelling gear CCF 	47,28 	75 102 100	Screw-on coupler 48 mm 	30 1,21 70 1,26 100 1,33 	95 100 100 95 102 100 95 104 100	
			Distance profile CCF 	7,99	75 114 000	Wind bracing 
Suspension profile CCF 	43,21	75 112 000	Positioning disk M30 	0,32	95 500 100	

Crane-climbing formwork CCF

Item		[kg]	Article n°	Item		[kg]	Article n°
Cone bolt M30x70		0,95	95 502 100				
							
Universal climbing cone		1,41	95 504 100				
							
Stone anchor	15.0mm 0.16m	0,43	99 200 100				
							
Sealing sleeve	15	0,008	99 104 400				
							

Climbing working platform CWP

Crane-jumped formwork system based on folding protection platforms.

CWP system is a reliable combination of Variant folding working platforms and framed or timber-beam formwork systems used as a crane-jumped formwork on sites where the formwork should be repositioned upwards in several casting sections, and in this case there is no need for retractable formwork use. CWP can also be used as a roof and edge protection system.

Load-bearing capacity:

- Loads on the suspension point: horizontal load - 36 kN, vertical load - 26 kN;
- Live load per unit area is 150 kg/m² acting on folding and working platforms;
- Formwork height of up to 3.75 m.

Cost-effective:

- Less crane-time is needed as the folding platform and formwork are moved up in one single lift;
- Wide range of formwork as the platform can be combined with either framed or timber-beam formwork.

Easy handling and planning:

- Small number of different parts used;
- Time and cost-effective solution owing to pre-assembled element use;
- The formwork can be quickly and precisely plumbed and aligned in all directions with a simple adjustment mechanism.

Safe use:

- Safe working conditions provided by 1.80 m fully railed-in working platform;
- Dependable suspension points with a certified suspension cone and lift-out guard for the brackets.



Climbing working platform CWP - System overview

Folding platform CWP (A) is a pre-assembled modular element, with nominal length of 3.00 or 4.50 m consisting of folding brackets, railings and decking. Distance between brackets is fixed at 1.50 m.

Folding bracket CWP (B) - reliable folding brackets, which bear and transfer loads of fresh concrete and live load of working and pouring platforms acting on the anchoring points and structure.

Suspended platform CWP (C) - additional working platform fixed under the folding platform and used for finishing work and as an access-way to the anchoring system after the system have been lifted by crane.

Connection shoe CWP (D) is used for connecting the folding bracket to the vertical waling and allows the entire climbing unit to be lifted and repositioned as one piece together with the formwork.







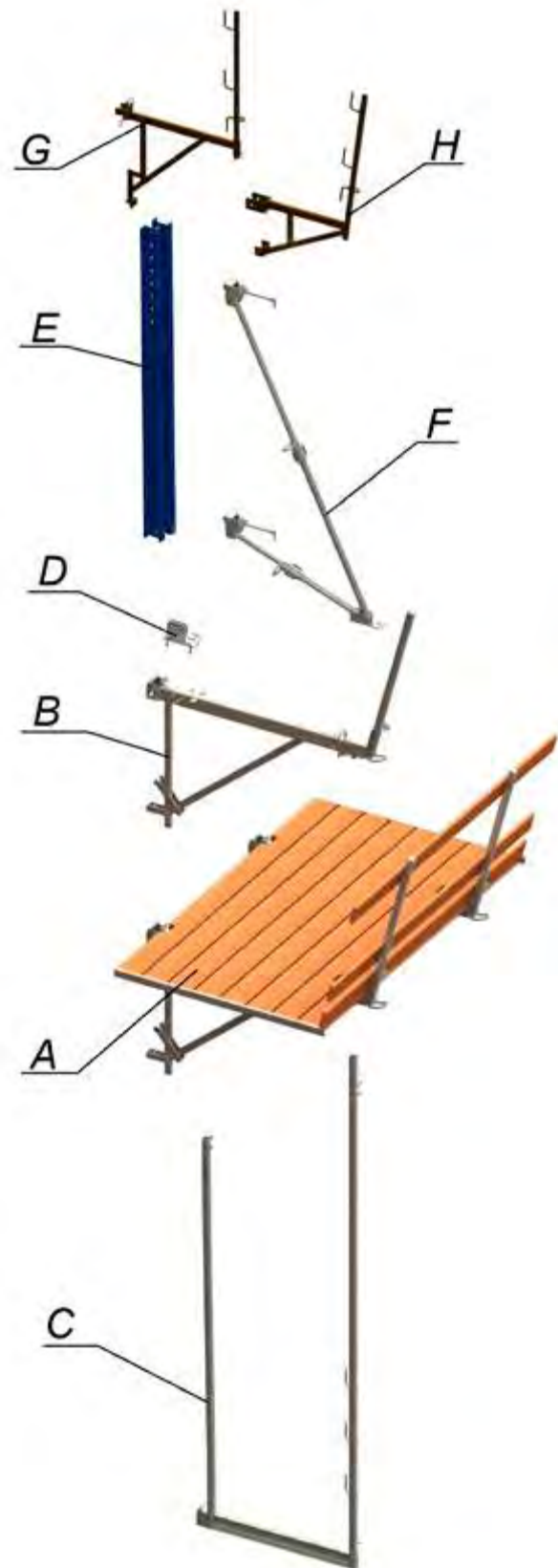





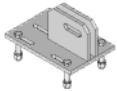

Vertical waling CWP (E) is used for holding the timber-beam or framed formwork. The length of this waling will depend on the height of the formwork elements or panels.

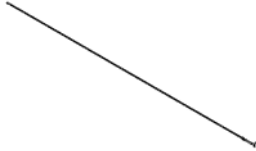
Supporting strut 340 (F) is used for aligning of the formwork elements or panels.





Wall bracket H20 (G) or Wall bracket Varimax (H) is used for assembling pouring platforms. Choose the relevant type of brackets depending on the formwork system used (timber-beam or framed).



Climbing working platform CWP

Item	[kg]	Article n°	Item	[kg]	Article n°
Folding bracket CWP 	65,40 ISO 3834	73 100 200	Supporting strut 340 	37,38 ISO 3834	11 928 100
Suspended platform CWP 3.30m 4.30m 	55,40 69,47 ISO 3834	73 102 000 73 104 000	Star screw CWP 	0,68	73 200 100
Connection shoe CWP 	6,58 ISO 3834	73 106 100	Guide rail clamp 	12,40 ISO 3834	52 400 100
Waling 12 3.00m 3.50m 4.00m 	63,53 75,33 85,47 ISO 3834	21 300 000 21 350 000 21 400 000	Wind bracing 7.00m 	17,47 ISO 3834	73 114 100
Adjusting spindle 	6,62 ISO 3834	32 102 100	Framed tube 48 mm 1.00m 1.50m 2.00m 2.50m 3.00m 	4,60 6,91 9,21 11,51 13,81	94 100 200 94 150 200 94 200 200 94 250 200 94 300 200
Wailing-to bracket holder 	2,61 ISO 3834	75 200 100	Swivel coupler 48x48mm 	1,22	95 106 100
Connecting pin 	0,39	23 400 100	Screw-on coupler 48 mm 30mm 70mm 100mm 	1,21 1,26 1,33 ISO 3834	95 100 100 95 102 100 95 104 100
Spring cotter 	0,05	23 402 100			

Climbing working platform CWP

Item		[kg]	Article n°	Item	[kg]	Article n°
Fixing plate	15	0,18	95 400 100			
						
Canrilever positioning cone	15	0,53	95 402 100			
						
Suspension cone	15	0,95	95 404 100			
						
Stop anchor	15.0mm 0.16m	0,43	99 200 100			
						
Sealing sleeve	15	0,008	99 104 400			
						



VARIANT

**SPECIAL
FORMWORK**

Configurable tunnel system UNIFORM

Quick project completion with less manpower.

Configurable tunnel formwork is a system that allows simultaneous casting of walls and slab in one pouring cycle. Half tunnels can be stripped and moved out to the next phase/level the next day after the pouring. Owing to quicker workflow and easy operation compared to conventional systems, the use of this system can save up to 50% of formwork budget. The system provides for making smooth concrete surface, achievement of dimensional accuracy and exclusion of such finishing works as plastering. Moreover, the system creates good load-bearing concrete structure that can be used for projects carried out in seismic areas.

Load-bearing capacity:

- High load-bearing capacity.

Cost-effective:

- Rapid pace of work and cutting of re-assembly costs, due to repositioning of complete units;
- High quality of concrete surface reduces finishing work to minimum;
- High number of use cycles (up to 500) results in lower follow-up expenses.

Easy handling and planning:

- Small number of different parts used;
- Time and cost-effective solution owing to the use of pre-assembled half tunnels;
- The formwork can be quickly and precisely plumbed and aligned in all directions.

Safe use:

- Safe working conditions provided by system safety equipment.



Configurable tunnel formwork UNIFORM

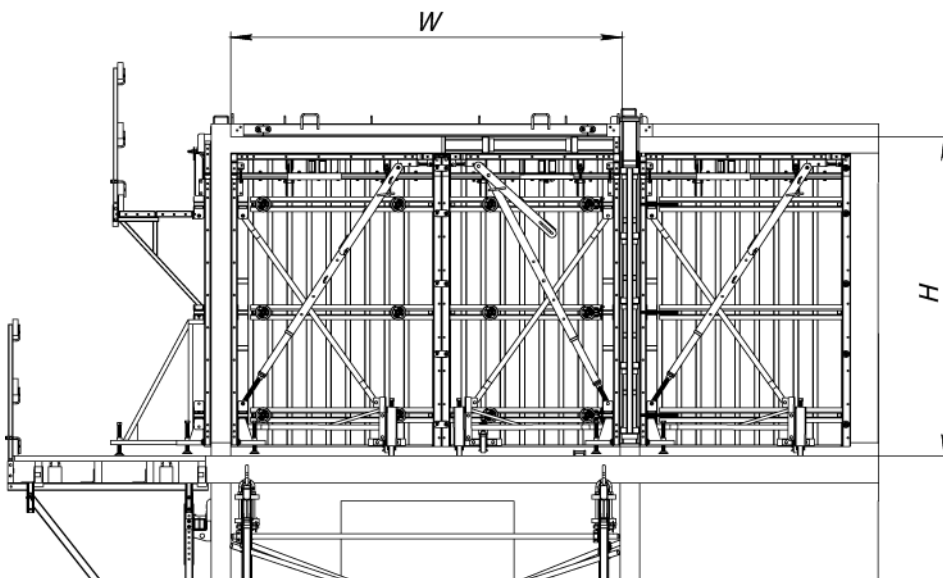
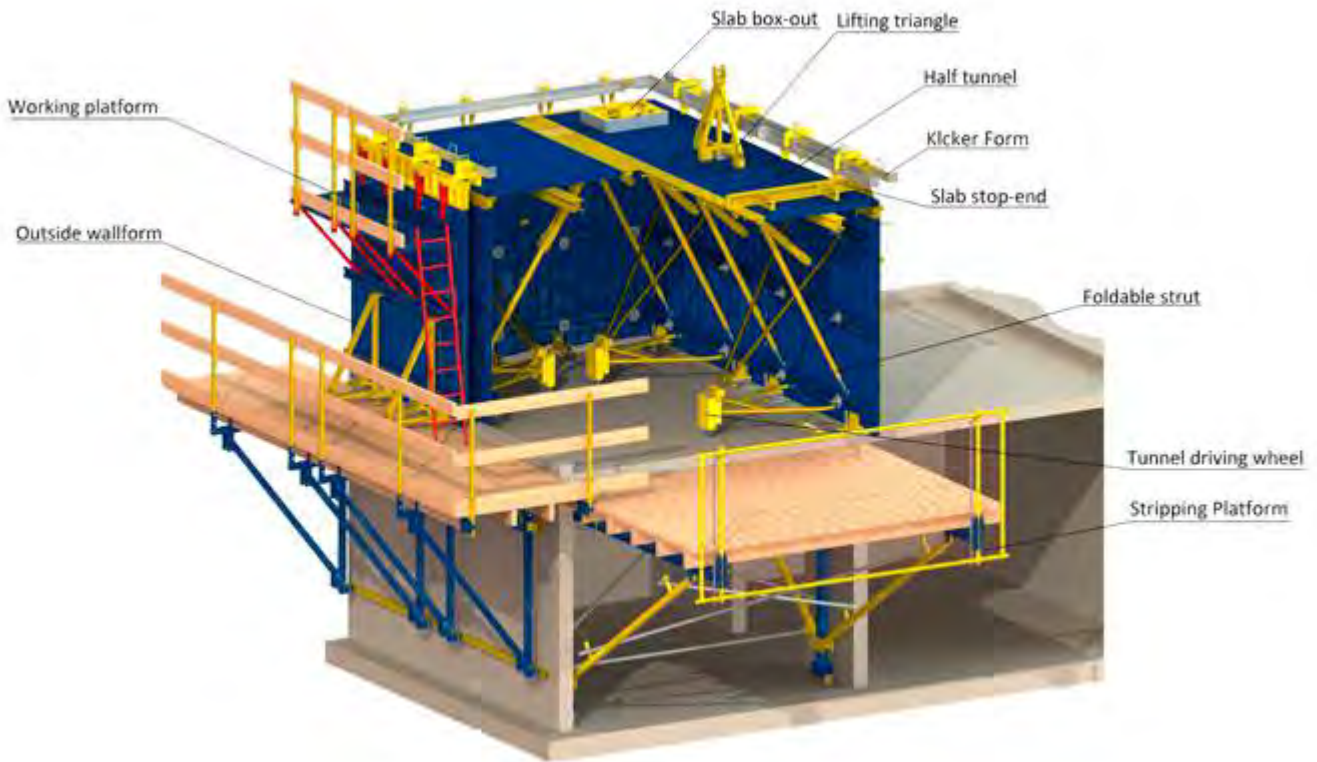

Standard span width W, mm
2100
2400
2700
3000
3300
3600
3900
4200
4500
4800
5100
Standard floor height H, mm
2750
2800
2850
2900
2950
3000
3050
3100

Configurable tunnel formwork UNIFORM – repositioning

Vertical repositioning:

Assembly hook is used for assembly only at the beginning.



Lifting Triangle is used for lifting and transportation of the configurable tunnel formwork.

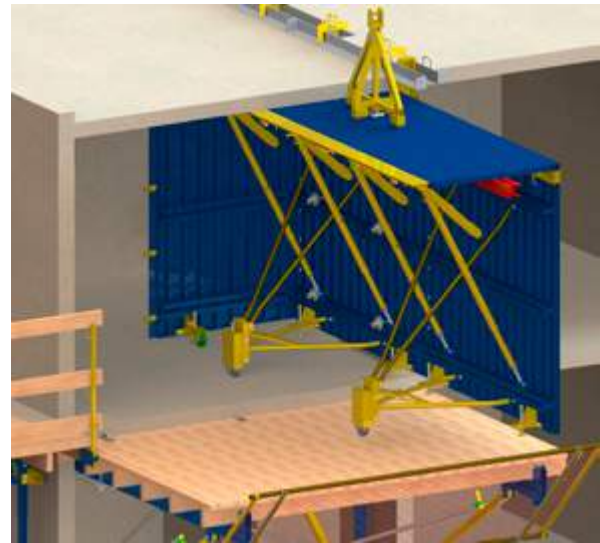

Horizontal repositioning:

Uniform has integrated wheels for shifting half tunnel blocks when assembling, dismantling, repositioning.

- Tunnel driving wheel Uniform:

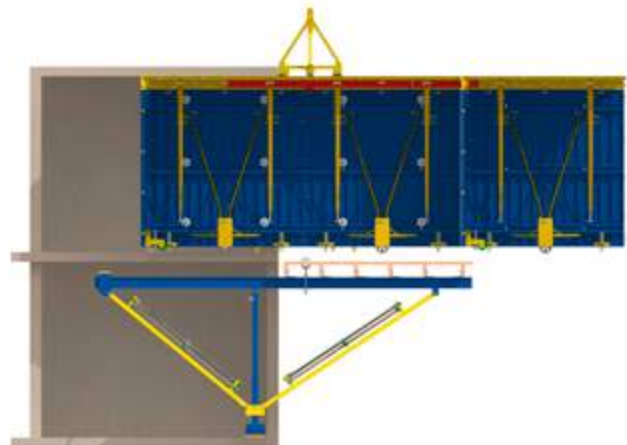



- Back panel jack and wheel Uniform:







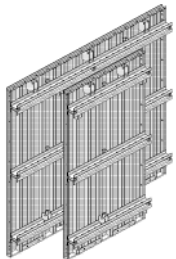
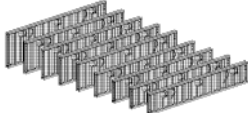
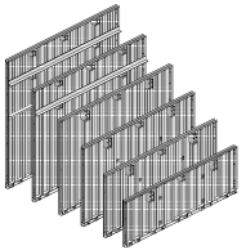
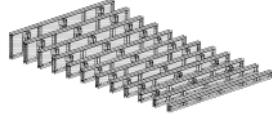
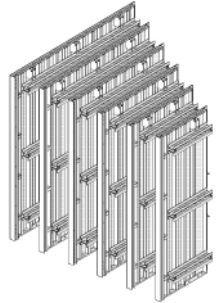
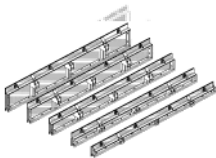
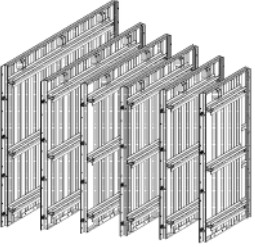

Roller



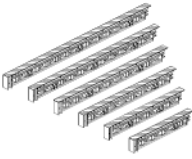

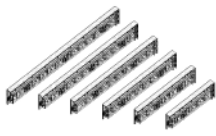

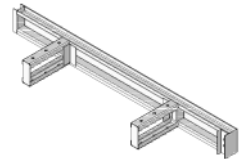



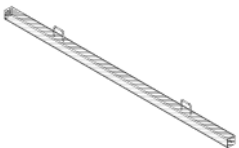

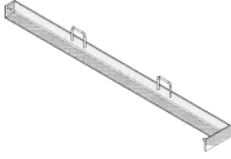

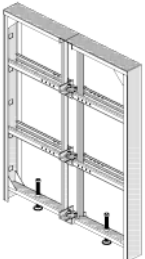
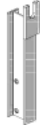

Half-tunnels can be easily moved and stripped on platforms with the help of rollers used instead of wheels. It is placed under vertical panel of half-tunnels above the slab and helps to reduce vertical forces when stripping.

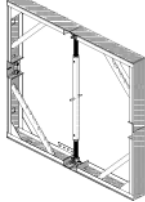

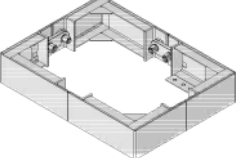



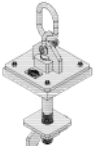





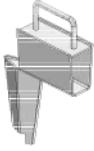



		[kg]	Article n°	Item		[kg]	Article n°
Vertical panel Uniform 	1250x2500	266,28	81 100 000	Vertical adapter external Uniform 	323x1250	33,47	83 200 000
	2500x2500	520,59	81 102 000		363x1250	36,31	83 204 000
	1250x2700	280,88	81 200 000		443x1250	41,99	83 208 000
	2500x2700	549,57	81 202 000		483x1250	44,82	83 212 000
						533x1250	48,38
					323x2500	63,88	83 216 000
					363x2500	69,48	83 220 000
					443x2500	80,65	83 224 000
					483x2500	86,24	83 228 000
					533x2500	93,23	83 230 000
Deck panel Uniform 	(850+63)x1250	79,23	81 300 000	Vertical adapter internal Uniform 	130x1250	16,17	83 104 000
	(1150+63)x1250	100,46	81 302 000		150x1250	17,14	83 106 000
	(1450+63)x1250	121,73	81 304 000		170x1250	19,85	83 110 000
	(1750+63)x1250	142,92	81 306 000		180x1250	20,29	83 112 000
	(1950+63)x1250	178,40	81 308 000		190x1250	20,79	83 114 000
	(2350+63)x1250	206,69	81 310 000		200x1250	21,27	83 116 000
	(850+63)x2500	151,75	81 400 000		220x1250	22,27	83 118 000
	(1150+63)x2500	193,66	81 402 000		250x1250	23,76	83 120 000
	(1450+63)x2500	235,46	81 404 000		350x1250	28,73	83 124 000
	(1750+63)x2500	277,32	81 406 000		130x2500	31,08	83 130 000
	(2050+63)x2500	341,85	81 408 000		150x2500	33,03	83 132 000
	(2350+63)x2500	406,59	81 410 000		170x2500	36,90	83 136 000
						180x2500	37,91
				190x2500	38,85	83 140 000	
				200x2500	40,43	83 142 000	
				220x2500	42,38	83 144 000	
				250x2500	45,33	83 146 000	
				350x2500	55,14	83 150 000	
Back panel left Uniform 	(1049+2500) L93	214,12	81 500 000	Deck panel adapter Uniform 	149x1250	23,15	83 300 000
	(1049+2700) L93	226,71	81 502 000		199x1250	26,37	83 302 000
	(1349+2500) L93	278,31	81 504 000		249x1250	30,20	83 304 000
	(1349+2700) L93	294,53	81 506 000		299x1250	32,70	83 306 000
	(1649+2500) L93	341,39	81 508 000		349x1250	35,20	83 308 000
	(1649+2700) L93	361,25	81 510 000		149x2500	45,52	83 310 000
	(1949+2500) L93	391,01	81 512 000		199x2500	50,88	83 312 000
	(1949+2700) L93	413,47	81 514 000		249x2500	57,24	83 314 000
	(2249+2500) L93	457,20	81 516 000		299x2500	61,64	83 316 000
	(2249+2700) L93	483,29	81 518 000		349x2500	66,03	83 318 000
	(2549+2500) L93	519,81	81 520 000				
	(2549+2700) L93	549,54	81 522 000				
Back panel right Uniform 	(1049+2500)R93	214,12	81 600 000	Grip Uniform  Options available: xx xxx 000 - Powder coated; xx xxx 100 - Galvanized	9,63	88 340 000	
	(1049+2700)R93	226,71	81 602 000				
	(1349+2500)R93	278,31	81 604 000				
	(1349+2700)R93	294,53	81 606 000				
	(1649+2500)R93	341,39	81 608 000				
	(1949+2700)R93	361,91	81 610 000				
	(1949+2500)R93	391,01	81 612 000				
	(1949+2700)R93	413,47	81 614 000				
	(2249+2500)R93	457,20	81 616 000				
	(2249+2700)R93	483,29	81 618 000				
	(2349+2500)R93	519,81	81 620 000				
	(2349+2700)R93	549,54	81 622 000				
				Diagonal Uniform  Options available: xx xxx 000 - Powder coated; xx xxx 100 - Galvanized	Code 2.9	11,50	88 342 000
					Code 3.3	13,10	88 346 000
					Code 3.7	14,72	88 350 000
					Code 4.2	16,74	88 354 000
					Code 4.7	18,75	88 358 000
					Code 5.3	21,18	88 362 000
				Code 5.5	21,98	88 364 000	

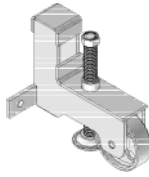

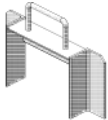
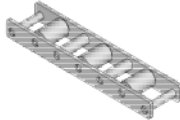

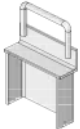







UNIFORM

		[kg]	Article n°	Item	[kg]	Article n°	
Back panel adapter left Uniform 	(1049+183) AL93	20,91	83 400 000	(1949+343) AR93	56,08	83 698 000	
	(1049+213) AL93	23,62	83 404 000	(1949+413) AR93	63,95	83 702 000	
	(1049+233) AL93	25,00	83 408 000	(2249+183) AR93	43,05	83 704 000	
	(1049+253) AL93	26,36	83 412 000	(2249+213) AR93	48,95	83 708 000	
	(1049+283) AL93	28,40	83 416 000	(2249+233) AR93	51,56	83 712 000	
	(1049+343) AL93	32,50	83 420 000	(2249+253) AR93	54,17	83 716 000	
	(1049+413) AL93	37,26	83 424 000	(2249+283) AR93	58,08	83 720 000	
	(1349+183) AL93	26,63	83 426 000	(2249+343) AR93	65,91	83 724 000	
	(1349+213) AL93	30,39	83 430 000	(2249+413) AR93	75,05	83 728 000	
	(1349+233) AL93	32,02	83 434 000	(2549+183) AR93	48,39	83 730 000	
	(1349+253) AL93	33,64	83 438 000	(2549+213) AR93	54,75	83 734 000	
	(1349+283) AL93	36,08	83 442 000	(2549+233) AR93	57,81	83 738 000	
	(1349+343) AL93	40,95	83 446 000	(2549+253) AR93	60,79	83 742 000	
	(1349+413) AL93	46,64	83 450 000	(2549+283) AR93	65,24	83 746 000	
	(1649+183) AL93	31,97	83 452 000	(2549+343) AR93	74,16	83 750 000	
	(1649+213) AL93	36,29	83 456 000	(2549+413) AR93	84,58	83 754 000	
	(1649+233) AL93	38,27	83 460 000				
	(1649+253) AL93	40,26	83 464 000				
	(1649+283) AL93	43,23	83 468 000				
	(1649+343) AL93	49,20	83 472 000				
	(1649+413) AL93	56,17	83 476 000				
	(1949+183) AL93	36,78	83 478 000				
	(1949+213) AL93	41,48	83 482 000				
	(1949+233) AL93	43,73	83 486 000				
	(1949+253) AL93	45,97	83 490 000				
	(1949+283) AL93	49,33	83 494 000				
	(1949+343) AL93	56,08	83 498 000				
	(1949+413) AL93	63,95	83 502 000				
	(2249+183) AL93	43,05	83 504 000				
	(2249+213) AL93	48,95	83 508 000				
	(2249+233) AL93	51,56	83 512 000				
	(2249+253) AL93	54,17	83 516 000				
	(2249+283) AL93	58,08	83 520 000				
	(2249+343) AL93	65,91	83 524 000				
	(2249+413) AL93	75,05	83 528 000				
	(2549+183) AL93	48,39	83 530 000				
	(2549+213) AL93	54,84	83 534 000				
	(2549+233) AL93	57,81	83 538 000				
	(2549+253) AL93	60,79	83 542 000				
	(2549+283) AL93	65,24	83 546 000				
	(2549+343) AL93	74,16	83 550 000				
	(2549+363) AL93	84,58	83 554 000				
							
	Back panel adapter right Uniform 	(1049+183) AR93	20,91	83 600 000	(1045+93)x150	18,73	85 200 000
		(1049+213) AR93	23,62	83 604 000	(1045+93)x180	20,42	85 204 000
(1049+233) AR93		25,00	83 608 000	(1045+93)x220	22,68	85 208 000	
(1049+253) AR93		26,36	83 612 000	(1045+93)x280	26,06	85 212 000	
(1049+283) AR93		28,40	83 616 000	(1345+93)x150	21,92	85 214 000	
(1049+343) AR93		32,50	83 620 000	(1345+93)x180	23,85	85 218 000	
(1049+413) AR93		37,26	83 624 000	(1345+93)x220	26,40	85 222 000	
(1349+183) AR93		26,63	83 626 000	(1345+93)x280	30,22	85 226 000	
(1349+213) AR93		30,39	83 630 000	(1645+93)x150	25,13	85 228 000	
(1349+233) AR93		32,02	83 634 000	(1645+93)x180	27,26	85 232 000	
(1349+253) AR93		33,64	83 638 000	(1645+93)x220	30,11	85 236 000	
(1349+283) AR93		36,08	83 642 000	(1645+93)x280	34,38	85 240 000	
(1349+343) AR93		40,95	83 646 000	(1945+93)x150	31,55	85 242 000	
(1349+413) AR93		46,64	83 650 000	(1945+93)x180	34,23	85 246 000	
(1649+183) AR93		31,97	83 652 000	(1945+93)x220	37,79	85 250 000	
(1649+213) AR93		36,29	83 656 000	(1945+93)x280	43,14	85 254 000	
(1649+233) AR93		38,27	83 660 000	(2245+93)x150	34,76	85 256 000	
(1649+253) AR93		40,26	83 664 000	(2245+93)x180	37,64	85 260 000	
(1649+283) AR93		43,23	83 668 000	(2245+93)x220	41,51	85 264 000	
(1649+343) AR93		49,20	83 672 000	(2245+93)x280	47,31	85 268 000	
(1649+413) AR93		56,17	83 676 000	(2545+93)x150	37,94	85 270 000	
(1949+183) AR93		36,78	83 678 000	(2545+93)x180	41,07	85 274 000	
(1949+213) AR93		41,48	83 682 000	(2545+93)x220	45,22	85 278 000	
(1949+233) AR93		43,73	83 686 000	(2545+93)x280	51,47	85 282 000	
(1949+253) AR93		45,97	83 690 000				
(1949+283) AR93		49,33	83 694 000				
							
					Wall stop-end Uniform		
					2823x178	59,87	85 100 000
					2823x198	62,41	85 102 000
					2843x178	60,10	85 108 000
					2843x198	62,64	85 110 000
					2933x178	61,13	85 112 000
					2933x198	63,73	85 114 000
					3033x178	62,27	85 116 000
					3033x198	64,91	85 118 000
							
					Slab stop-end Uniform		
					(1045+93)x150	18,73	85 200 000
					(1045+93)x180	20,42	85 204 000
					(1045+93)x220	22,68	85 208 000
					(1045+93)x280	26,06	85 212 000
					(1345+93)x150	21,92	85 214 000
					(1345+93)x180	23,85	85 218 000
					(1345+93)x220	26,40	85 222 000
				(1345+93)x280	30,22	85 226 000	
				(1645+93)x150	25,13	85 228 000	
				(1645+93)x180	27,26	85 232 000	
				(1645+93)x220	30,11	85 236 000	
				(1645+93)x280	34,38	85 240 000	
				(1945+93)x150	31,55	85 242 000	
				(1945+93)x180	34,23	85 246 000	
				(1945+93)x220	37,79	85 250 000	
				(1945+93)x280	43,14	85 254 000	
				(2245+93)x150	34,76	85 256 000	
				(2245+93)x180	37,64	85 260 000	
				(2245+93)x220	41,51	85 264 000	
				(2245+93)x280	47,31	85 268 000	
				(2545+93)x150	37,94	85 270 000	
				(2545+93)x180	41,07	85 274 000	
				(2545+93)x220	45,22	85 278 000	
				(2545+93)x280	51,47	85 282 000	
							
				Kicker form inner L12			
				Uniform			
				1498	24,24	87 100 100	
				1798	28,86	87 102 100	
				2098	33,48	87 104 100	
				2398	38,10	87 106 100	
				2698	42,72	87 108 100	
				2998	47,34	87 110 100	
				3298	51,96	87 112 100	
				3598	56,58	87 114 100	
				3898	61,20	87 116 100	
				4198	65,82	87 118 100	
				4498	70,44	87 120 100	
							
							







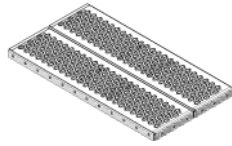





		[kg]	Article n°	Item		[kg]	Article n°
Kicker form straight L12 Uniform 	625	13,00	87 122 100	Wheel connector Uniform  Options available: xx xxx 000 - Powder coated xx xxx 100 - Galvanized	850-1150	19,48	87 168 000
	1200	21,89	87 124 100		1450-1750	23,72	87 170 000
	1250	22,67	87 126 100		2050-2650	26,10	87 172 000
	2400	40,46	87 128 100				
	2500	42,01	87 130 100				
	3750	61,35	87 132 100				
	4500	77,60	87 134 100				
	5000	80,68	87 136 100				
Kicker form corner L12 Uniform 	(2593x299) L	45,99	87 138 100	Lifting beam Uniform  Options available: xx xxx 000 - Powder coated xx xxx 100 - Galvanized xx xxx 200 - Hot dip galvanized	1000	22,50	87 174 000
	(2593x299) R	45,99	87 140 100		2000	40,93	87 176 000
					3000	59,36	87 178 000
					4000	78,73	87 180 000
					5000	97,05	87 182 000
							
Door boxout Uniform 	1600x2013x178	135,63	87 154 000	Upper panel support Uniform  Options available: xx xxx 000 - Powder coated xx xxx 100 - Galvanized xx xxx 200 - Hot dip galvanized	377	2,79	87 184 000
	1600x2013x198	143,34	87 156 000		387	2,86	87 186 000
					397	2,92	87 188 000
					407	2,98	87 190 000
					417	3,05	87 192 000
					437	3,16	87 194 000
					487	3,48	87 196 000
					537	3,78	87 198 000
Window boxout Uniform 	1600x1420x148	97,82	87 158 000	567	3,97	87 200 000	
				587	4,08	87 202 000	
				637	4,40	87 204 000	
							
Slab boxout Uniform 	600x800x148	42,12	87 160 000	Lifting triangle 	70,56		87 206 000
	800x800x148	46,58	87 162 000				
							
Foldable strut Uniform 	2500	36,97	87 164 000	Assembly hook 	11,89		87 208 000
	2700	38,06	87 166 000				
							

UNIFORM

		[kg]	Article n°	Item	[kg]	Article n°								
Kicker spacer single sided L12 Uniform 	v:148 v:150	3,76	87 210 000	Vertical panel jack Uniform  Options available: xx xxx 000 - Powder coated xx xxx 100 - Galvanized	8,26	87 330 000								
	v:158 v:150	3,90	87 212 000											
	v:178 v:150	4,19	87 214 000											
	v:198 v:150	4,48	87 216 000											
	v:248 v:150	5,21	87 218 000											
	v:298 v:150	5,94	87 220 000											
	v:148 v:180	4,00	87 222 000											
	v:158 v:180	4,15	87 224 000											
	v:178 v:180	4,44	87 226 000											
	v:198 v:180	4,74	87 228 000											
	v:248 v:180	5,46	87 230 000											
	v:298 v:180	6,18	87 232 000											
	v:148 v:220	4,34	87 246 000											
	v:158 v:220	4,48	87 248 000											
	v:178 v:220	4,78	87 250 000											
	v:198 v:220	5,06	87 252 000											
	v:248 v:220	5,80	87 254 000											
v:298 v:220	6,52	87 256 000												
														
Kicker spacer double sided L12 Uniform 	v:148 v:150	5,10	87 258 000	Tunnel driving wheel Uniform  Options available: xx xxx 000 - Powder coated xx xxx 100 - Galvanized	23,17	87 332 000								
	v:158 v:150	5,25	87 260 000											
	v:178 v:150	5,54	87 262 000											
	v:198 v:150	5,83	87 264 000											
	v:248 v:150	6,56	87 266 000											
	v:298 v:150	7,29	87 268 000											
	v:148 v:180	5,60	87 270 000											
	v:158 v:180	5,74	87 272 000											
	v:178 v:180	6,04	87 274 000											
	v:198 v:180	6,33	87 276 000											
	v:248 v:180	7,06	87 278 000											
	v:298 v:180	7,79	87 280 000											
	v:148 v:220	6,27	87 294 000											
	v:158 v:220	6,42	87 296 000											
	v:178 v:220	6,70	87 298 000											
	v:198 v:220	6,99	87 300 000											
	v:248 v:220	7,73	87 302 000											
v:298 v:220	8,45	87 304 000												
														
Kicker clamp single sided L12 Uniform  Options available: xx xxx 000 - Powder coated; xx xxx 100 - Galvanized	148	3,07	87 306 000	Back panel jack and wheel Uniform  Options available: xx xxx 000 - Powder coated xx xxx 100 - Galvanized	8,97	87 336 000								
	158	3,12	87 308 000											
	178	3,22	87 310 000											
	198	3,32	87 312 000											
	248	3,57	87 314 000											
	298	3,83	87 316 000											
														
	Kicker clamp double sided L12 Uniform  Options available: xx xxx 000 - Powder coated; xx xxx 100 - Galvanized	148	2,79				87 318 000	Roller Uniform  Options available: xx xxx 000 - Powder coated xx xxx 100 - Galvanized	53-R	87 338 000				
		158	2,85				87 320 000		73-R		10,62			
		178	2,94				87 322 000							
		198	3,05				87 324 000							
		248	3,30				87 326 000							
		298	3,55				87 328 000							
														
		Concrete stopper L12 Uniform 	148				2,03		87 142 100		Driver lever bolt Uniform  Options available: xx xxx 000 - Powder coated xx xxx 100 - Galvanized	100	0,32	87 340 100
			158				2,11		87 144 100			150	0,42	87 342 100
			178				2,29		87 146 100			200	0,53	87 344 100
198			2,47	87 148 100	250	0,63	87 346 100							
248			2,92	87 150 100	300	0,74	87 348 100							
298			3,36	87 152 100	350	0,84	87 350 100							
														
						Hinge bolt Uniform  Options available: xx xxx 000 - Powder coated xx xxx 100 - Galvanized	€30		0,14			87 352 100		

		[kg]	Article n°	Item	[kg]	Article n°	
Tie rod d20dC 	700	1,93	87 354 100	Panel clamp Uniform 	0,78	87 392 000	
	800	2,21	87 356 100				
	900	2,48	87 358 100				
Superplate 	SG20	1,60	87 360 100	Connector Uniform  Options available: xx xxx 000 - Powder coated xx xxx 100 - Galvanized	51-G	1,47	87 394 100
					90-G	3,80	87 396 100
Cotter US 	45x60	0,29	87 362 100	External panel support Uniform  Options available: xx xxx 000 - Powder coated xx xxx 100 - Galvanized	28,50	87 398 000	
							
Dilatation tie cone d25TC  Options available: xx xxx 000 - Powder coated xx xxx 100 - Galvanized	148	1,71	87 364 100	 Options available: xx xxx 000 - Powder coated xx xxx 100 - Galvanized	28,50	87 398 000	
	178	1,97	87 366 100				
	218	2,56	87 370 100				
	248	3,13	87 372 100				
	298	3,98	87 374 100				
	348	4,46	87 376 100				
Spacer Uniform  Options available: xx xxx 000 - Powder coated xx xxx 100 - Galvanized xx xxx 200 - Hot dip galvanized	85-115 (2500)	7,93	87 378 000	Ladder Uniform  Options available: xx xxx 000 - Powder coated xx xxx 100 - Galvanized	16,26	87 400 000	
	145-175 (2500)	9,03	87 380 000				
	205-235 (2500)	9,78	87 382 000				
	85-115 (2700)	8,66	87 384 000				
	145-175 (2700)	9,66	87 386 000				
	205-235 (2700)	10,36	87 388 000				
Lifting beam clamp Uniform  Options available: xx xxx 000 - Powder coated xx xxx 100 - Galvanized xx xxx 200 - Hot dip galvanized		4,36	87 390 000	Perforated deck Uniform  Options available: xx xxx 000 - Powder coated xx xxx 100 - Galvanized xx xxx 200 - Hot dip galvanized	1250	20,63	87 402 000
					2500	41,27	87 404 000

UNIFORM

	[kg]	Article n°	Item	[kg]	Article n°	
Platform support Uniform  Options available: xx xxx 000 - Powder coated xx xxx 100 - Galvanized xx xxx 200 - Hot dip galvanized	6,21	87 406 000	Spacer Uniform  Options available: xx xxx 000 - Powder coated xx xxx 100 - Galvanized	1500 2000 2500	14,02 18,23 22,44	88 110 000 88 112 000 88 114 000
Platform bracket Uniform  Options available: xx xxx 000 - Powder coated xx xxx 100 - Galvanized xx xxx 200 - Hot dip galvanized	0,91	87 408 000	Shoe Uniform  Options available: xx xxx 000 - Powder coated xx xxx 100 - Galvanized		11,14	88 116 000
Guardrail post  Options available: xx xxx 000 - Powder coated xx xxx 100 - Galvanized	6,31	87 410 000	Guardrail post holder Uniform  Options available: xx xxx 000 - Powder coated xx xxx 100 - Galvanized		3,53	88 118 000
Cantilever Uniform 	77,89	88 100 000	Cantilever Uniform 	6FP 7FP 8FP	239,97 261,31 322,15	88 260 000 88 270 000 88 280 000
Spacer Uniform  Options available: xx xxx 000 - Powder coated xx xxx 100 - Galvanized	1500 2000 2500	22,51 28,72 34,92	Brace Uniform  Options available: xx xxx 000 - Powder coated xx xxx 100 - Galvanized	Code 1.8 Code 2.4 Code 3.0 Code 3.6 Code 4.2 Code 4.5	10,54 12,96 15,38 17,80 20,22 21,43	88 300 000 88 304 000 88 308 000 88 312 000 88 316 000 88 318 000
Extension Uniform  Options available: xx xxx 000 - Powder coated xx xxx 100 - Galvanized	19,65	88 108 000	Guardrail  Options available: xx xxx 000 - Powder coated xx xxx 100 - Galvanized	L=2.2m L=2.8m L=3.4m L=4.0m L=4.6m L=4.9m	55,99 60,95 65,93 70,90 82,82 85,31	88 320 000 88 324 000 88 328 000 88 332 000 88 336 000 88 338 000

VARIANT

**We provide
your support
from the
project
beginning till
its completion**

Custom made formwork

Custom made forms for structures of any shape or size.

Steel forms produced at customer's request are mainly used for forming concrete elements of special or non-standard shapes when conventional systems are not applicable or difficult to use.

System adaptability:

Variant custom-made steel formwork is especially suitable for forming:

- Bridge pylons;
- Concrete elements with curved surfaces of several directions;
- Precast concrete elements including bridge girders, columns, etc.

Variant custom made steel formwork reduces time needed to prepare and assembly forms at a construction site, provides exact geometrical shape of a structure formed and has high load-bearing capacity comparing to site-made forms.

Load-bearing capacity:

- The system can be customized to withstand almost any load of fresh concrete.

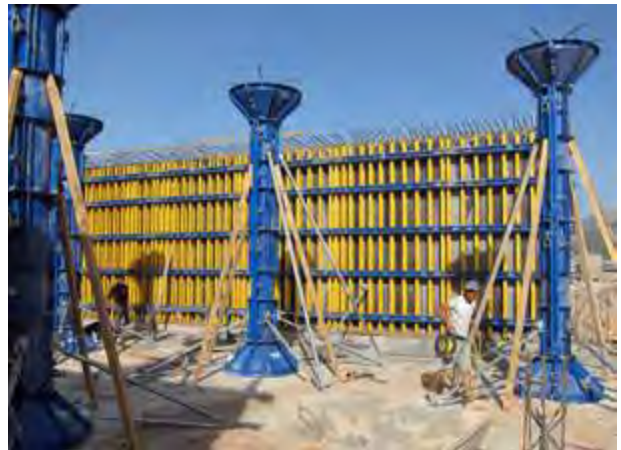

Custom made formwork

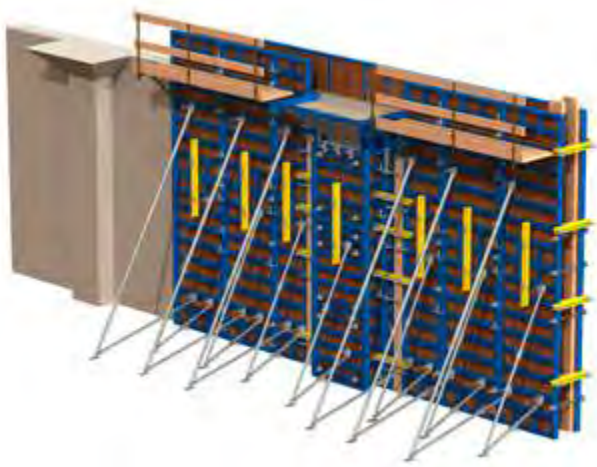



VARIANT

**SAFETY
SYSTEMS**

Folding brackets CWP

Suspended scaffold platforms for safe and practical construction work.

The system of working/protective platforms is based on the Variant folding brackets CWP. This system can be easily pre-assembled in ready to use platforms. With only one crane lift the whole platform can be installed/ shifted or reinstalled to a new working area. Owing to system versatility the folding brackets CWP can be used to do all types of construction and safety tasks.

Depending on your construction needs you can use the folding brackets CWP as:

- working platforms;
- protective platforms;
- sloping-rooftop fall barriers;
- protective canopies.

Load-bearing capacity:

- High load-bearing capacity of up to 600 kg/m^2 provides for placement of wall formwork up to 5.5 m high on the platforms;
- Depending on load class, live loads acting on working and pouring platforms per unit area vary:
 - Class 2 - 150 kg/m^2 ;
 - Class 3 - 200 kg/m^2 ;
 - Class 4 - 300 kg/m^2 ;
 - Class 5 - 450 kg/m^2 ;
 - Class 6 - 600 kg/m^2 .
- Loads that act on the suspension point when using suspension cone as an anchoring system - vertical load (V)=24 kN, horizontal load (H)=14 kN.

Safe use:

- Safe working conditions provided by fully railed working platform;
- Dependable anchoring system of suspension cone.

Cost-effective:

- Reduced labor and crane times due to the use of pre-assembled units;
- Logical concept of the system makes planning and installation easier;
- The system is ready for use after making some quick and easy operations;
- Long service life owing to its sturdy design and galvanized steel construction.



Folding bracket CWP- System overview



There are 2 possible lengths of pre-assembled platforms, as required by the situation:

- 3.00 m (2 brackets)
- 4.50 m (3 brackets)

Pre-assemble platform of folding brackets CWP 3.00 m consisting of the following elements:

- Folding bracket CWP (A)**
- Planks, min. 20x5 cm (site-provided) (B)**
- Guard-rail boards, min 15x3 cm (site-provided) (C)**
- Framed tube 48 mm (D)**
- Screw-on coupler 48 mm (E)**
- Swivel coupler 48x48 mm (F)**

Suspension points are always spaced with the same distance of approximately 1.50 m and 0.75 m from the platform edge that facilitates planning and installation

Placement of the suspension points at the structure corner.

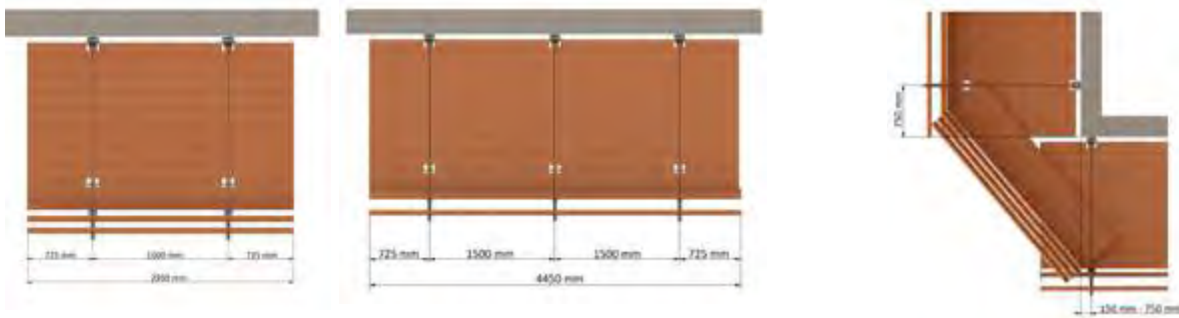

Folding bracket CWP – Areas of use















Working platform

With formwork	Without formwork



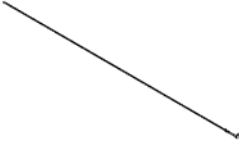



Protection platform

Fall barrier	Sloping-rooftop fall barrier	Protective canopy

Folding brackets CWP

Item		[kg]	Article n°	Item		[kg]	Article n°
Folding bracket CWP 		65,40	73 100 200	Connecting pin D16/112 		0,30	73 202 100
				Spring cotter for Connecting pin D16/112 		0,05	73 204 100
Suspended platform 	3.30m 4.30m	55,40 69,47	73 102 000 73 104 000	Connecting pin 		0,39	23 400 100
				Spring cotter 		0,05	23 402 100
				Star screw CWP 		0,68	73 200 100
Support girder CWP 		30,00	73 110 100	Guide rail clamp 		12,40	52 400 100
Strut CWP 		32,97	73 112 100	Wind bracing 	7.00m	17,47	73 114 100
				Framed tube 48 mm 	1.00m 1.50m 2.00m 2.50m 3.00m	4,60 6,91 9,21 11,51 13,81	94 100 200 94 150 200 94 200 200 94 250 200 94 300 200
Bearing profile CWP 		5,04	73 108 100				
Waling 12 	2.75m 3.50m	58,20 75,33	21 275 000 21 350 000	Swivel coupler 	48x48mm	1,22	95 106 100

Folding brackets CWP

Item		[kg]	Article n°	Item	[kg]	Article n°
Screw-on coupler 48 mm 	30	1,21	95 100 100			
	70	1,26	95 102 100			
	100	1,33	95 104 100			
						
Fixing plate 	15	0,18	95 400 100			
Cantilever positioning cone 	15	0,53	95 402 100			
Suspension cone 	15	0,95	95 404 100			
Stop anchor 	15.0mm 0.16m	0,43	99 200 100			
Sealing sleeve 	15	0,008	99 104 400			

Shaft platform

Crane-jumped platform for shaft concreting.

The Variant crane-climbing platform combined with Variant wall formwork system is an efficient and safe way of shaft wall concreting. Owing to the stripping corner use wall formwork can be easily closed and opened just with a spindle turn. The whole set of wall formwork, shaft platform and additional suspended platform can be repositioned by one lifting of a crane. The main part of shaft platform is a telescopic shaft beam. It is an element bearing the loads of formwork and working platforms and allowing easy adaptation to any dimension of shaft structure. Moreover, the telescopic shaft beam has a gravity head. Installed inside precast hole the head allows platform shifting with a crane only upwards. The system serves as a support for wall formwork and as a safe area for maintenance of wall formwork.

Load-bearing capacity:

- Max. support load of the telescopic beam - 20 kN;
- Live load on a shaft platform - 2 kN/m².

System adaptability:

- Excellent adaptability to any shaft dimension;
- Swift and precise formwork adjustment in all directions.

Cost-effective:

- Reduced labor and crane time;
- Fast and simple way of system pre-assembly and installation;
- The entire unit can be safely and quickly repositioned as one piece.

Easy handling and planning:

- Small number of different parts used;
- Any architectural requirements for concrete wall design can be met.

Safe use:

- Safe working conditions provided by gravity head of the telescopic beams.



Shaft platform - System overview

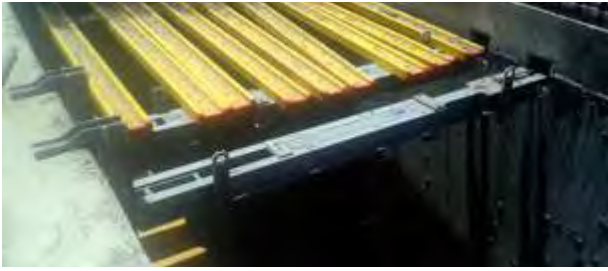

The system serves as:

- support for wall formwork;
- safe platform for maintenance of the wall formwork.

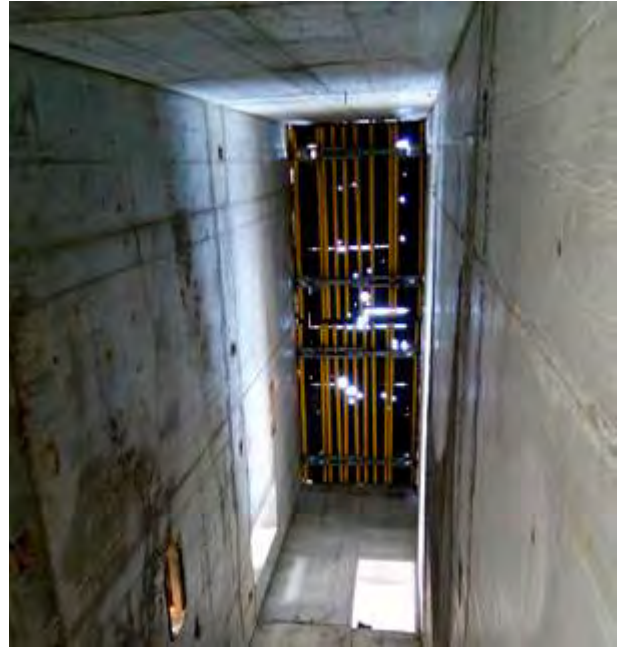





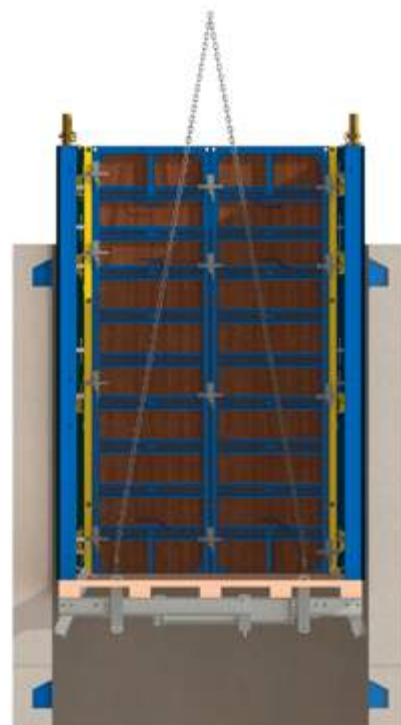





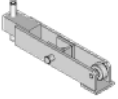

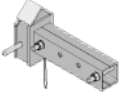
Shaft platform - System repositioning

Owing to heads integrated in the telescopic shaft beams, the whole set of the shaft system can be lifted upwards to the next pouring area. Only one crane lift is required for the whole system to be relocated. Once the gravitation head reaches new precast hole, it goes inside it and since that moment a reliable support is provided. Then the whole system is ready for a new concreting cycle.



Shaft platform

Item	[kg]	Article n°	Item	[kg]	Article n°	
	1.45-1.65m	63,72	71 100 200	Beam screw 	60	23 302 100
	1.65-2.00m	72,05	71 102 200		110	23 304 100
	2.00-2.70m	108,89	71 104 200			
	2.70-3.80m	153,59	71 106 200			
	3.80-5.90m	248,30	71 108 200			
						
Gravity shaft beam head		19,62	71 200 200			
						
Anchored shaft beam head		18,25	71 202 200			
						
Hanging shaft beam head		30,92	71 204 200			
						
Box for latch		2,70	71 300 000			
						
Shaft beam suspension 4.0...4.5		22,15	71 400 200			
						
Waling 12	1.00m	21,00	21 100 000			
	1.25m	26,25	21 125 000			
	1.50m	31,82	21 150 000			
	1.75m	37,07	21 175 000			
	2.00m	42,32	21 200 000			
	2.25m	47,46	21 225 000			
	2.50m	52,71	21 250 000			
	2.75m	58,28	21 275 000			
	3.00m	63,53	21 300 000			
						



Guardrails

Effective protection against fall hazard on any construction site.

Guide rail clamp

Owing to convenient and reliable clamp system the guide rail clamp can be easily fixed to any horizontal structure on site such as edge of a slab, wooden girders, formwork H20 beams, etc. to provide construction personnel with fall protection in accordance with safety norms and rules. When the crew is properly protected, they work safely and quickly and, thus, more efficiently for your success.

System adaptability:

- Excellent adaptability to any application owing to the clamp system.

Cost-effective:

- Reduces time needed for installation, dismantling and transportation to the next area to minimum;
- High number of use cycles results in lower follow-up expenses;
- Galvanized or powder-coated for long service life.

Easy handling and planning:

- Convenient and easy to mount owing to fixing method;
- Only one tool, a hammer, is required.

Safe use:

- Uninterrupted or powder-coated at any construction phase.

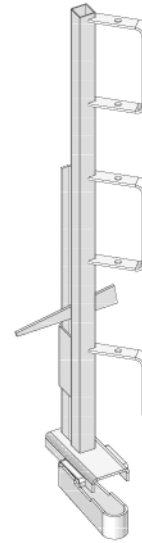

Handrail post

Owing to reliable bolt system the handrail post can be easily fixed to H20 beam to provide construction personnel with fall protection in accordance with safety norms and rules. When the crew is properly protected, they work safely and quickly and, thus, more efficiently for your success.

System adaptability:

- Versatile edge protection. It is used with Variable edge tables, bridge edge beam formwork, etc.

Cost-effective:

- Once installed, it can be moved and dismantled with formwork as one assembled gang-form;
- High number of use cycles results in lower follow-up expenses;
- Galvanized or powder-coated for long service life.

Easy handling and planning:

- Convenient and easy to mount owing to fixing method;
- Only one tool, a ratchet wrench, is required.

Safe use:

- Uninterrupted safety at any construction phase.

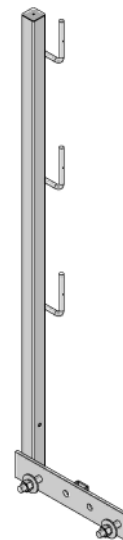

Guardrails – system in use

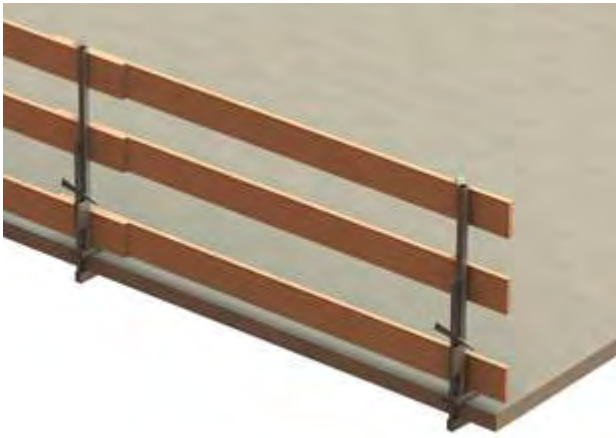

The guide rail clamp can be fixed on any finished concrete slabs to provide construction personnel with protection against fall hazard.

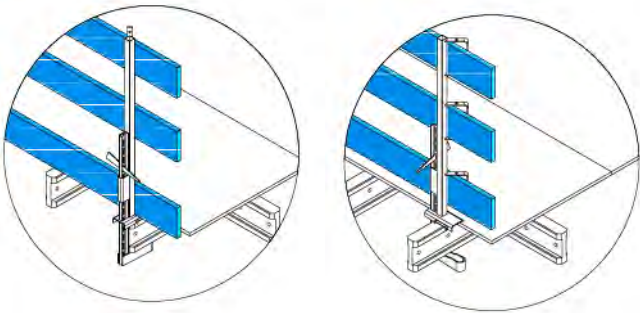

The guide rail clamp can be fixed at any point of the timber formwork beam. H20 beam should be secured against overturning!



Stair tower TT40

Access system which can help attain any height quickly and safely.

Stair tower TT40 by Variant is a modular stair tower system based on Variant scaffolding system TopTower40. The stair tower system has been designed to provide fast and safe access to a working area at height. Owing to its simple assembly this system is convenient and easy to erect with minimal efforts. Optimized speed of access to a working area at height ensures efficient labor-hours use. Moreover, aspect of the system safety helps to prevent accidents at your construction site. Intermediate exits provide for safe access to any level. The Stair tower gets the most use out of your equipment: both stair towers and load-bearing towers can be assembled using the same system.

Load-bearing capacity:

- Maximum stair tower height is 100 m;
- Live load is 150 kg/m².

Cost-effective:

- Labor-hours are used more efficiently due to quick access during works executed at height;
- Easy and fast assembly, only a hammer is required as an assembly tool;
- All parts of the stair tower are galvanized (HDG) for long service life;
- High number of use results in lower follow-up expenses.

Easy handling and planning:

- Small number of different components is used;
- It can be lifted by crane as a complete tower or as pre-assembled units;
- It is time and cost-effective owing pre-assembled element use;
- It can be used in space-tight areas, system dimensions are 1.5x2.5 m.

Safe use:

- Safe working conditions provided by fully railed stair tower;
- Dependable stability of the stair tower.



Stair tower TT40 - System overview



- (A) Scaffold frame TT40 1.2x1.5
- (B) Lower support TT40
- (C) Outer railing
- (D) Inner railing
- (E) Access railing TT40
- (F) Landing railing
- (G) Stair TT40
- (H) Reinforcing adapter TT40

For reliable use and safe repositioning of assembled (pre-assembled) units by a crane, the stair tower TT40 has an interconnection system. It consists of insert TT40 installed between two frames and fixed by retainers TT40

Stair tower TT40 - Anchoring

Distance from structure is up to 1.00 m



Distance from structure ranges from 1.00 m up to max. 2.50 m

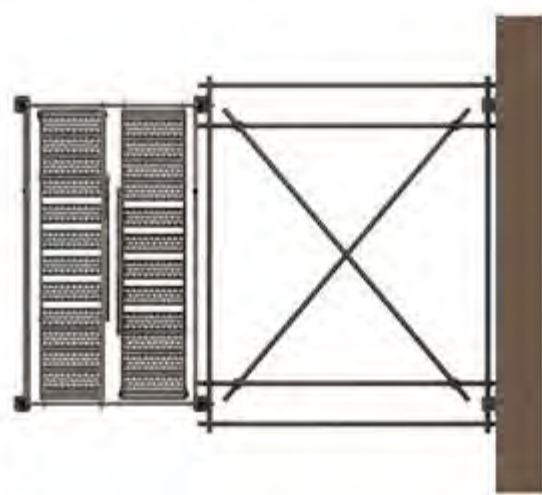











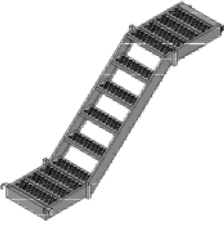

For Stair Tower with anchoring distance of up to 40 m:

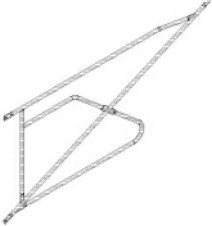
- with/without netting - every 5th frame;
- with tarpaulins - every 4th frame.

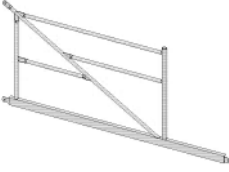
For Stair Tower with anchoring distance ranging from 40 to 100 m:

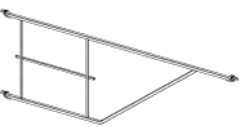
- with/without netting - every 4th frame;
- with tarpaulins - every 3rd frame.

Stair tower TT40

Item	[kg]	Article n°	Item	[kg]	Article n°
Scaffold frame TT40 1.20x1.50m 	18,91	61 120 200	Reinforcing adapter TT40 	13,84	64 410 200
Stairs TT40 	40,52	64 400 200	Insert TT40 	0,89	61 400 100
			Retainer TT40 	0,06	61 402 100
Outer railing TT40 	14,97	64 402 200	Lower Support TT40 	11,09	61 502 100
			Inner railing TT40 	6,63	64 404 200
Access railing TT40 	33,15	64 406 200	Anti-dropout lock TT40 	0,59	61 404 100
			Framed tube 	1.00m 4,60 1.50m 6,91 2.00m 9,21 2.50m 11,51 3.00m 13,81	94 100 200 94 150 200 94 200 200 94 250 200 94 300 200
Landing railing TT40 	12,20	64 408 200	Swivel coupler 	48x48mm 1,22	95 106 100
			Screw-on coupler 48 mm 	30 1,21 70 1,26 100 1,33	95 100 100 95 102 100 95 104 100
			Anchoring shoe 	5,03	61 800 100

Touching the clouds

variant-factory.eu



VARIANT

REUSABLE PACKAGING

Packaging items

Reusable packaging and storing items for better on site logistics.

Multi-use packing items such as containers, stacking pallets and skeleton transport boxes will help to keep your construction site in order thus minimizing the time spent on finding all the necessary formwork parts (small items and accessories) during installation and improving logistics when pouring zone change is required. The stacking pallets simplify storage and handling of slab props, folding tripods, formwork beams. The skeleton transport box is a good means to store and handle lighter accessories (max. load 250 kg). For heavier accessories, there is plenty of space in a packaging container (max. load 1000 kg).

Cost-effective:

- Fast loading and unloading of system components, small items and accessories;
- All the equipment can be easily transported by crane with minimal efforts;
- Equipment can be efficiently stored even on sites with limited storage areas.

Folding wire mesh container

(based on Euro-pallet 1200 x 800 mm)



Dimensions 800x1200xh	Weight	Max. load	Wire mesh
800 mm	29.6 kg	250 kg	50x50 mm
1000 mm	35.6 kg		
1200 mm	41.6 kg		

Transportation box



Dimensions 1200x800x800 mm	Weight	Max. load
	120 kg	1000 kg

Stacking pallet



Dimensions	Weight	Max. load
1550x850x750 mm	41.5 kg	900 kg
1700x950x1000 mm	50 kg	

Stacking pallet may be provided on quick-mount wheels with brakes.





325, Shevchenko Street
Kharkiv, 61070, Ukraine

Tel. +38 (057) 756-37-77
E-mail: international@variant-factory.eu

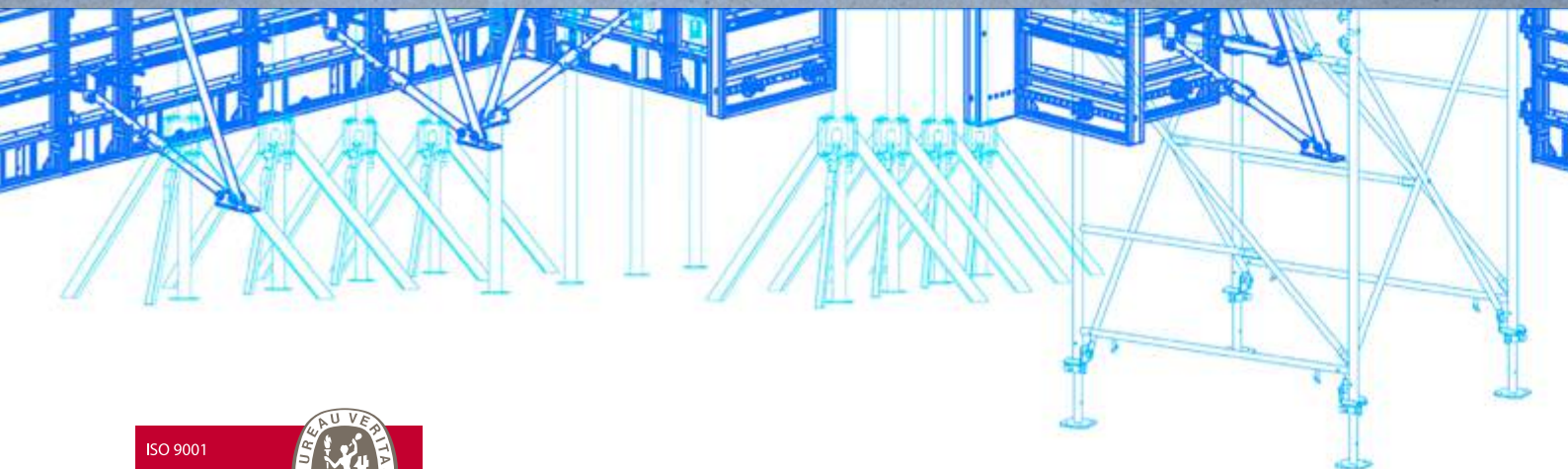

ISO 9001
BUREAU VERITAS
Certification



N° UA228513